

PT25 / PT25L

INVERTED BUCKET STEAM TRAPS



DESCRIPTION:

Inverted bucket steam trap with integral strainer and all stainless steel internals. Best suited for equipment drains with medium to heavy condensate loads. Intermittent operation.

FEATURES:

The inverted bucket arrangement operates on the density difference between steam and water, giving a cyclic operation for discharge of the accumulated condensate.

High condensate handling capacities even at low pressure, permit the use of small trap sizes to suit many applications.

The valve and valve seat are hardened by a special induction hardening process to withstand continuous prolonged operation.

Perfect shut-off, no steam loss.

SIZES: DN15, 20, 25, 40, 50

CONNECTIONS: Screwed (NPT, BSPT, BSP) /
Socket Weld / Flanged*

*End connection flanges of ASTM A105 forged carbon steel are welded on.

Non IBR/IBR approved

LIMITING CONDITIONS:

PMA: Max. allowable pressure	25 bar(g)
TMA: Max. allowable temp. (DN15 ~ 25 size) (DN40, 50 size)	25 @ 425 °C 25 @ 343 °C 18 @ 425 °C
Maximum operating back pressure at the outlet should not exceed 90% of the inlet pressure.	
Minimum diff. pressure for satisfactory operation	0.1 bar
Cold hydro test pressure	38 bar(g)

INSTALLATION:

The trap should be fitted with the inlet and outlet connections horizontally in-line. Correct fitment with body vertical is essential for easy movement of the bucket. Care must be taken to ensure that the trap level is below the level of the equipment to be drained. The bypass arrangement should be above the level of the trap.

Full port isolation valves should be fitted before and after the trap, to be used when the trap has to be opened for maintenance.

MAINTENANCE:

This product can be maintained inline without disturbing the piping connections. Ensure that the trap is isolated - upstream & downstream - before attempting to dismantle it. It is recommended that the trap be opened periodically and the internals inspected for wear, damage, and dirt. All worn or damaged parts should be replaced with new spares. A full new internal kit comprising of the valve pin, valve seat, bracket and lever, should be replaced as a set. The bucket vent hole should be cleaned. The strainer screen should be removed and cleaned regularly.

IMPORTANT:

Ensure that the trap is primed by opening the inlet valve only a crack at start-up, allowing water to fill the trap before the steam enters. The inlet valve should be opened fully only after the trap is filled with water.

The trap should be installed as close as possible to the equipment to be drained.

For new pipelines, ensure that the lines are properly flushed, prior to fitting the trap.

MATERIAL:

NO.	PART	MATERIAL	QTY. (Nos.)
1.	BODY	ASTM A216 Gr. WCB	01
2.	COVER	ASTM A216 Gr. WCB	01
3.	BUCKET ASSEMBLY	AISI 304 with CS reinforcing ring	01
4.	LEVER ASSEMBLY	AISI 304	01
5.	VALVE SEAT (Hardened)	AISI 410/420	01
6.	BRACKET	AISI 304	01
7.	VALVE PIN (Hardened)	AISI 410/420	01
8.	STRAINER SCREEN	AISI 304 (Perforated Sheet 0.8)	01
9.	STRAINER CAP	ASTM A216 Gr. WCB	01
10.	GASKET (COVER)	Graphite with SS304 Reinforced	01
11.	GASKET (STRAINER)	Graphite with SS304 Reinforced	01
12.	BOLT	ASTM A193 Gr. B7	*
13 & 14.	PLUG	CARBON STEEL	01 each
15.	PIPE	MILD STEEL	01

* Sizes : Upto DN25 - 06 Nos., DN40 & 50 - 08 Nos

DIMENSIONS: Nominal in mm

MODEL	SIZE	A	B	C	D	Wt.**	E	
							#150	#300
PT25	DN15	180	219	126	141	08 kg	257	269
	DN20	245	295	169	227	19 kg	325	335
	DN25	282	330	182	262	31 kg	368	381
	DN40	378	470	255	324	60 kg	477	490
	DN50	378	470	255	324	60 kg	477	490
PT25L*	DN20	180	219	126	141	08 kg	260	270
	DN25	245	295	169	227	19 kg	331	345

* Low capacity trap ** For traps with screwed/socket weld ends

AVAILABLE SPARES:

SPARE KIT: Valve Pin, Valve Seat, Bracket & Lever Assly.,
(Op. diff. press. should be specified)
Bucket Assly, Gaskets, Strainer Screen

HOW TO ORDER:

PT25 DN25 BSP ΔP NIBR

ORDERING INFORMATION:

- 1) Inlet Pressure in bar(g)
- 2) Back Pressure in bar(g)
- 3) Operating Temperature in °C
- 4) Condensate Load in kg/hr
- 5) Size & Model
- 6) End Connections
- 7) IBR/NIBR

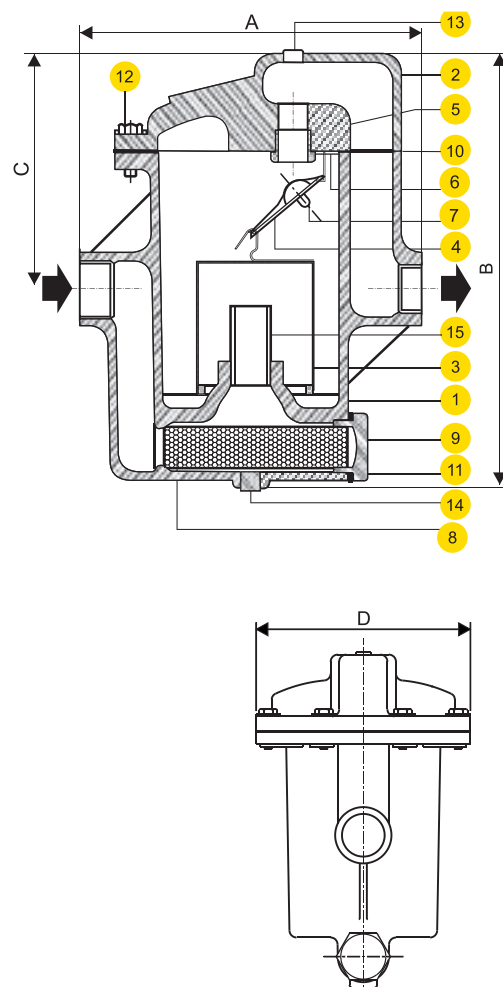

CONTINUOUS DISCHARGE CAPACITY OF TRAPS IN KILOGRAMS OF HOT CONDENSATE PER HOUR

Model	Orifice Size	DIFFERENTIAL PRESSURE (bar)																						
		0.25	0.5	1.0	2.0	3.0	4.0	5.0	6.0	7.0	8.0	9.0	10.0	11.0	12.0	13.0	14.0	15.0	16.0	17.5	19.0	21.0	23.0	25.0
PT25-15 PT25L-20	2.5	80	100	120	150	180	200	220	230	250	260	270	280	290	300	310	315	330	340	350	370	390	410	430
	2.8	90	120	170	230	260	310	350	390	420	460	480	520	560	580	620	650	680	710	730	-	-	-	-
	3.2	120	150	200	280	340	380	430	480	540	580	620	660	700	740	780	-	-	-	-	-	-	-	-
	4.0	150	220	290	380	450	520	580	650	720	780	-	-	-	-	-	-	-	-	-	-	-	-	-
	4.8	320	380	460	600	680	750	800	-	-	-	-	-	-	-	-	-	-	-	-	-	-	-	-
	6.4	360	470	600	720	-	-	-	-	-	-	-	-	-	-	-	-	-	-	-	-	-	-	-
PT25-20 PT25L-25	4.0	150	220	290	380	450	520	580	650	720	780	850	940	1000	1080	1150	1250	1350	1430	1500	1550	1600	1680	1800
	4.8	320	350	400	520	620	720	800	880	950	1025	1075	1175	1250	1300	1400	1500	1600	1700	1850	-	-	-	-
	5.6	340	400	480	650	780	900	1025	1100	1175	1275	1375	1500	1600	1725	1850	1950	-	-	-	-	-	-	-
	6.4	380	450	600	850	1075	1200	1300	1425	1575	1700	1875	2000	2100	-	-	-	-	-	-	-	-	-	-
	7.9	500	620	760	1000	1175	1325	1475	1650	1800	1900	-	-	-	-	-	-	-	-	-	-	-	-	-
	8.7	640	740	900	1150	1325	1500	1700	1900	-	-	-	-	-	-	-	-	-	-	-	-	-	-	-
PT25-25	9.5	950	1150	1300	1600	1900	-	-	-	-	-	-	-	-	-	-	-	-	-	-	-	-	-	
	12.5	1200	1450	1700	-	-	-	-	-	-	-	-	-	-	-	-	-	-	-	-	-	-	-	
	4.8	320	350	400	520	620	720	800	880	950	1025	1075	1175	1250	1300	1400	1500	1600	1700	1850	2000	2200	2350	2500
	6.4	380	420	650	1000	1200	1400	1600	1800	2000	2150	2300	2500	2650	2800	2950	3100	3300	3450	3700	-	-	-	-
	7.0	500	640	1000	1400	1750	2000	2250	2500	2650	2800	2900	3050	3250	3400	3600	3800	4000	-	-	-	-	-	-
	7.9	700	900	1150	1700	2100	2500	2750	3000	3300	3600	3800	4000	4200	4400	-	-	-	-	-	-	-	-	-
PT25-40 PT25-50	8.7	850	1100	1500	2000	2500	2900	3200	3500	3700	3900	4100	-	-	-	-	-	-	-	-	-	-	-	
	9.5	1000	1200	1600	2250	2800	3300	3650	3850	4100	-	-	-	-	-	-	-	-	-	-	-	-	-	
	11.2	1200	1500	1900	2500	3250	3800	-	-	-	-	-	-	-	-	-	-	-	-	-	-	-	-	
	14.3	1500	2100	2850	4100	-	-	-	-	-	-	-	-	-	-	-	-	-	-	-	-	-	-	-
	19.0	2300	3400	4000	-	-	-	-	-	-	-	-	-	-	-	-	-	-	-	-	-	-	-	-
	9.5	1000	1200	1600	2250	2800	3300	3650	3850	4100	4400	4700	5100	5500	6000	6400	6800	7200	7600	8000	8500	9000	9800	10800
11.0	1200	1500	2050	2750	3450	4000	4700	5200	5800	6200	6800	7300	7800	8000	8500	9000	9300	9700	10000	-	-	-	-	
13.0	1600	2100	3000	4150	5000	5800	6600	7200	7900	8700	9300	9800	10200	10500	-	-	-	-	-	-	-	-	-	
15.0	2600	3400	4600	6300	7700	8600	9200	9900	-	-	-	-	-	-	-	-	-	-	-	-	-	-	-	
20.5	3600	4600	6400	8100	9100	-	-	-	-	-	-	-	-	-	-	-	-	-	-	-	-	-	-	
27.5	5000	6300	7800	9000	-	-	-	-	-	-	-	-	-	-	-	-	-	-	-	-	-	-	-	
32.0	6400	8500	10000	-	-	-	-	-	-	-	-	-	-	-	-	-	-	-	-	-	-	-	-	

GUIDELINES ON USE OF CAPACITY CHART

- Go to the differential pressure column corresponding to or slightly higher than, but not less than the operating differential pressure at which the trap is to be used. Move vertically downwards and select a suitable model and orifice size.
 - The selected capacity should be equal to or higher than the condensate load after including a safety factor of 2 to 3. Oversizing is not recommended.
 - Example - Operating conditions = I) Inlet press. 4 bar(g) II) Back press. 1 bar(g) III) Condensate load 480 kg/hr. IV) Safety factor 2.
- Model Selected: PT25-20 • Orifice size : 6.4mm • Capacity 1075 kg/hr @ a diff. press. of 3 bar.**