

# PT24/PT24L

## INVERTED BUCKET STEAM TRAPS



### DESCRIPTION:

Inverted bucket steam trap with all stainless steel internals, for high pressure steam systems.

### FEATURES:

The inverted bucket arrangement operates on the density difference between steam and water, giving a cyclic operation for discharge of the accumulated condensate.

High condensate handling capacities even at low pressures, permit the use of small trap sizes to suit many applications.

The valve and valve seat are hardened by a special induction hardening process to withstand continuous, prolonged operation.

Perfect shut-off, no steam loss.

Robust, maintenance-free, fully guaranteed.

### SIZES:

DN15, 20, 25, 40, 50

### CONNECTIONS:

Socket Weld / Flanged\*

\*End connection flanges are welded on.

**Non IBR/IBR approved**

### LIMITING CONDITIONS:

	ASTM A216 Gr - WCB	ASTM A217 Gr - WC6
PMA: Max. allowable pressure	63 bar(g)	65 bar(g)
TMA: Max. allowable temp.	425° C	510 °C
Maximum operating back pressure at the outlet should not exceed 90% of the inlet pressure		
Minimum diff. pressure for satisfactory operation	0.1 bar	0.1 bar
Cold hydro test pressure	95 bar(g)	98 bar(g)

### INSTALLATION:

The trap must be fitted vertically, with the inlet from the bottom and the outlet at the top. Correct vertical fitment is essential for easy movement of the bucket. Care must be taken to ensure that the trap level is below the level of the equipment to be drained. The bypass arrangement should be above the level of the trap.

Fitment of a strainer before the trap inlet is recommended to prevent entry of dirt/foreign particles into the trap. Full-port isolation valves should be fitted before and after the trap, to be used when the trap has to be opened for maintenance.

### MAINTENANCE:

This product has to be removed from the line for maintenance. It is recommended that the trap be opened periodically and the internals inspected for wear, damage and dirt. All worn or damaged parts should be replaced with new spares. A new internal kit comprising of the valve pin, valve seat, bracket and lever should be replaced as a set. The bucket vent hole should be cleaned.

### IMPORTANT:

Ensure that the trap is primed by opening the inlet valve only a crack, at commissioning, allowing water to fill the trap before the steam enters. Once steam enters, the inlet valve should be opened fully.

The trap should be installed as close as possible to the equipment to be drained. For new pipelines, ensure that the lines are properly flushed, prior to fitting the trap.

## MATERIAL:

NO.	PART	MATERIAL	QTY. (Nos.)
1.	BODY	ASTM A216 Gr-WCB**	01
2.	COVER	ASTM A216 Gr-WCB**	01
3.	BUCKET ASSEMBLY	AISI 304 with CS reinforcing ring	01
4.	VALVE SEAT (Hardened)	AISI 410/ 420	01
5.	VALVE PIN (Hardened)	AISI 410/ 420	01
6.	LEVER	AISI 304	01
7.	GASKET	CAF	01
8.	BOLTS	ASTM A193 Gr. B7	*
9.	NUTS	ASTM A194 Gr. 2H	*
10.	BRACKET ASSEMBLY	AISI 304	01
11.	PIPE	CARBON STEEL	01

Note: All internal screws are AISI 304

\* Varies with trap size (10 ~ 12)

\*\*ASTM A217 GR-WC6 on request

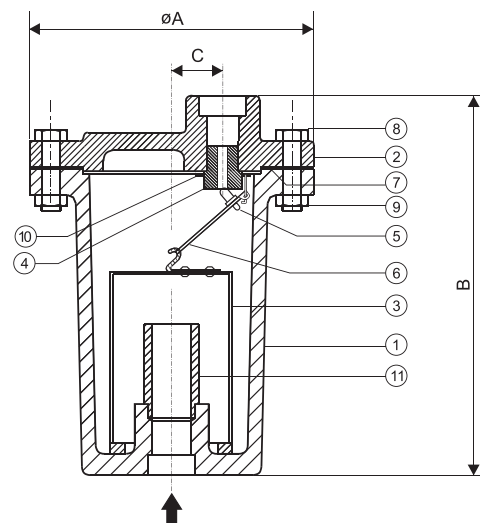

## DIMENSIONS:

Nominal in mm

MODEL	SIZE	A	B	C	Wt.##
PT24	DN15	138	178	19	7 kg
	DN20	200	265	36	18 kg
	DN25	238	285	37	30 kg
	DN40	310	379	48	55 kg
	DN50	310	379	48	55 kg
PT24L*	DN20	138	181	18	7 kg
	DN25	200	265	36	18 kg

## AVAILABLE SPARES:

SPARE KIT: (Op. diff. press. should be specified) Valve Pin, Valve Seat, Bracket, Lever, Bucket, Gasket.

## HOW TO ORDER:

PT24-25 DN40 SW ΔP

## FLANGED TRAPS (FACE TO FACE DIMENSIONS)

MODEL	SIZE	#150	#300	#600
PT24	DN15	253	243	265
	DN20	343	353	355
	DN25	349	381	385
	DN40	449	483	489
PT24L-20*	DN20	260	272	285
PT24L-25*	DN25	357	370	383

(\* Low capacity trap)

## For traps with socket weld ends

## ORDERING INFORMATION:

- 1) Inlet Pressure in bar(g)
- 2) Back Pressure in bar(g)
- 3) Operating Temperature in °C
- 4) Condensate Load in kg/hr
- 5) Size & Model
- 6) End Connections
- 7) IBR / NIBR

Model	Valve Size mm	DIFFERENTIAL PRESSURE (bar)																						
		0.25	0.5	1.0	2.0	3.0	4.0	5.0	6.0	7.0	8.0	9.0	10.0	11.0	12.0	13.0	14.0	15.0	16.0	17.5	19.0	21.0	23.0	25.0
PT24-15 PT24L-20	2.5	90	100	120	150	180	200	220	230	250	260	270	280	290	300	310	315	330	340	350	370	390	410	430
	2.8	100	120	170	230	260	310	350	390	420	460	480	520	560	580	620	650	680	710	730	-	-	-	-
	3.2	125	150	200	280	340	380	430	480	540	580	620	660	700	740	780	-	-	-	-	-	-	-	-
	4.0	150	220	290	380	450	520	580	650	720	780	-	-	-	-	-	-	-	-	-	-	-	-	-
	4.8	320	380	460	600	680	750	800	-	-	-	-	-	-	-	-	-	-	-	-	-	-	-	-
	6.4	360	470	600	720	-	-	-	-	-	-	-	-	-	-	-	-	-	-	-	-	-	-	-
	4.0	170	250	325	420	480	550	625	725	850	925	1050	1175	1325	1425	1525	1600	1680	1770	1840	1920	1980	2050	2100
PT24-20 PT24L-25	4.8	300	380	460	620	790	930	1075	1200	1350	1475	1600	1725	1850	1950	2100	2200	2300	2400	2500	-	-	-	-
	5.6	400	510	700	940	1150	1325	1525	1700	1850	2025	2100	2250	2350	2425	2500	-	-	-	-	-	-	-	-
	6.4	500	640	880	1200	1450	1700	1950	2200	2300	2400	2500	-	-	-	-	-	-	-	-	-	-	-	-
	7.0	620	840	1150	1530	1910	2300	2400	2500	-	-	-	-	-	-	-	-	-	-	-	-	-	-	-
	7.9	900	1200	1500	2050	2400	2600	-	-	-	-	-	-	-	-	-	-	-	-	-	-	-	-	-
	9.5	1300	1550	1900	2500	-	-	-	-	-	-	-	-	-	-	-	-	-	-	-	-	-	-	-
	12.5	1800	2125	2400	-	-	-	-	-	-	-	-	-	-	-	-	-	-	-	-	-	-	-	-
PT24-25	5.6	400	510	700	940	1150	1325	1525	1700	1850	2025	2100	2250	2350	2425	2500	2575	2650	2725	2790	2860	2920	2980	3025
	6.4	500	650	900	1200	1450	1700	1950	2200	2300	2425	2575	2650	2775	2900	3100	3350	3500	3650	3700	3750	-	-	-
	7.0	650	850	1150	1530	1910	2300	2550	2700	2850	2980	3150	3280	3400	3550	3775	3950	4150	-	-	-	-	-	-
	8.7	1000	1225	1650	2150	2500	2900	3200	3500	3700	3900	4100	-	-	-	-	-	-	-	-	-	-	-	-
	9.5	1300	1550	1900	2500	2800	3300	3800	4100	-	-	-	-	-	-	-	-	-	-	-	-	-	-	-
	11.2	1400	1700	2100	2800	3300	3800	4100	-	-	-	-	-	-	-	-	-	-	-	-	-	-	-	-
	14.3	1950	2350	3000	4100	4300	-	-	-	-	-	-	-	-	-	-	-	-	-	-	-	-	-	-
PT24-40	19.0	2300	3400	4000	-	-	-	-	-	-	-	-	-	-	-	-	-	-	-	-	-	-	-	
	9.5	1350	1600	1950	2550	2800	3350	3700	3950	4200	4400	4700	5100	5500	6000	6400	6800	7200	7600	8000	8400	8750	9150	9400
	11.2	1400	1750	2200	2950	3500	4000	4700	5300	5900	6450	6950	7450	7900	8300	8700	9100	9400	9700	10000	-	-	-	-
PT24-50	12.7	1550	2050	2900	4000	4800	5600	6400	7000	7700	8500	9100	9600	10100	-	-	-	-	-	-	-	-	-	-
	14.3	2100	2600	3500	4500	5400	6300	7200	7900	8500	9100	9600	10100	-	-	-	-	-	-	-	-	-	-	-
	15.0	2600	3400	4600	6300	7700	8600	9200	9700	10100	-	-	-	-	-	-	-	-	-	-	-	-	-	-
	20.5	3600	4600	6400	8100	9100	9800	-	-	-	-	-	-	-	-	-	-	-	-	-	-	-	-	-
	27.5	5000	6500	8500	10100	-	-	-	-	-	-	-	-	-	-	-	-	-	-	-	-	-	-	-
32.0	6400	8500	10000	-	-	-	-	-	-	-	-	-	-	-	-	-	-	-	-	-	-	-	-	

**GUIDELINES ON USE OF CAPACITY CHART**

- Go to the differential pressure column corresponding to or slightly higher than, but not less than the operating differential pressure at which the trap is to be used. Move vertically downwards and select a suitable model and valve size.
- The selected capacity should be equal to or higher than the condensate load after including a safety factor of 2 to 3. Oversizing is not recommended.
- Example - Operating conditions = I) Inlet press. 4 bar(g) II) Back press. 1 bar(g) III) Condensate load 480 kg/hr. IV) Safety factor 2.

**Model Selected: PT24-20 • Valve Size : 5.6mm • Capacity 1150 kg/hr @ a diff. press. of 3 bar.**