

PT14HP

THERMODYNAMIC STEAM TRAPS

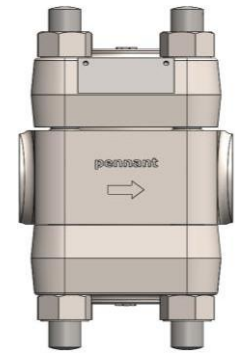

DESCRIPTION:

Thermodynamic steam trap with full stainless-steel internals. Best suited for high pressure line drains with low to medium condensate loads.

FEATURES:

- Complete stainless-steel internals ensure better mechanical & corrosion resistance properties.
- Condensate entry below the disc, concentric to the disc/seat ensures a clean & parallel lift of the disc with reference to the seat, eliminating localized wear & tear.
- The disc & seat are fully hardened by a special hardening process, to withstand continuous, prolonged operation.
- Perfect shut off, no steam loss.
- Robust, maintenance free, fully guaranteed.

SIZES: DN15, 20, 25

CONNECTIONS: Socket Weld/Butt Weld

Non-IBR/IBR approved

LIMITING CONDITIONS:

MOC	ASTM A182 Gr. F22 CL3		ASTM A182 F91
Class	PN250	#1500	#2500
PMA: Max. allowable pressure	250 bar(g) @ 300° C	258.5 bar(g) @ 38° C	430.9 bar(g) @ 38° C
TMA: Max. allowable temperature*	550° C up to 80 bar(g)	550° C up to 77 bar(g)	550° C up to 220 bar(g)
Maximum operating back pressure at the outlet should not exceed 50% of the inlet pressure			
Max. operating pressure**	220 bar(g) @ 374° C		
Max. operating temperature	550° C @ 80 bar(g)		
Minimum differential pressure for satisfactory operation	8 bar		
Cold hydro test pressure	375 bar(g)	388 bar(g)	647 bar(g)

* Can be supplied for higher temperature on request.

**Above 170 bar(g), a reduction in working life may be experienced.

INSTALLATION:

The trap will operate in any position, but the preferred installation is in a horizontal position with the disc seat cover on top. Full port isolating valves should be installed upstream and downstream of the trap. After the first 24 hours of service the cover nuts should be checked for tightness.

MAINTENANCE:

The disc and seat should be inspected for wear.

All worn or damaged parts should be replaced with new spares. The disc seat is replaceable. Ensure that all gaskets are replaced every time the trap is dismantled.

ALLOW THE TRAP TO COOL BEFORE DISMANTLING.

IMPORTANT:

To prevent water logging, it is required that the line be drained using the bypass, at start-up.

The trap should be installed as close as possible to the equipment to be drained.

For new pipelines, ensure that the lines are properly flushed, prior to fitting the trap.

MATERIAL:

NO.	PART	MATERIAL		QTY. (Nos.)
		PN250/#1500	#2500	
1	BODY			1
2	COVER	ASTM A182 Gr. F22 CL3	ASTM A182 Gr. F91	1
3	STRAINER COVER			1
4	DISC	STELLITE6		1
5	DISC SEAT	ASTM A681 Gr. D2 (HARDENED)		1
6	GASKET- OUTER	SPIRAL WOUND GASKET WITH GRAPHITE SS		2
7	GASKET-INNER			1
8	LOCATOR (INLET)	AISI 304		1
9	TUBE (OUTLET)	AISI 304		1
10	STUD FOR COVER	ASTM A193 Gr. B16		4
11	NUT FOR COVER	ASTM A194 Gr. 7		4
12	SINTERED STRAINER	SINTERED SS		1
13	STUD FOR STRAINER COVER	ASTM A193 Gr. B16		4
14	NUT FOR STRAINER COVER	ASTM A194 Gr. 7		4
15	SCREEN PLUG	AISI 304		1
16	LABEL	SS304		1

DIMENSIONS:

Nominal in mm

Socket Weld/Butt Weld Traps

END CONNS.	SIZE	A	B	C	Wt.
S/W, B/W	DN15, 20, 25	106	84	78	8.6 kg

AVAILABLE SPARES:

Set of internal working parts:- Disc, Disc seat, Set of gaskets, Strainer Sintered (packet of 5)

HOW TO ORDER:

PT14HP DN25 SW IBR

ORDERING INFORMATION:

- 1) Inlet Pressure in bar(g)
- 2) Back Pressure in bar(g)
- 3) Operating Temperature in °C
- 4) Condensate Load in kg/hr
- 5) Size & Model
- 6) End Connections
- 7) IBR/Non-IBR

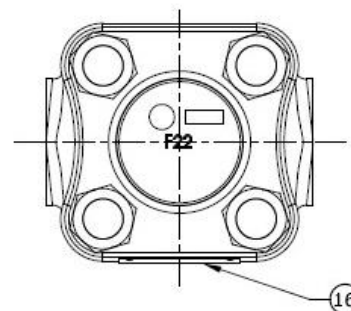
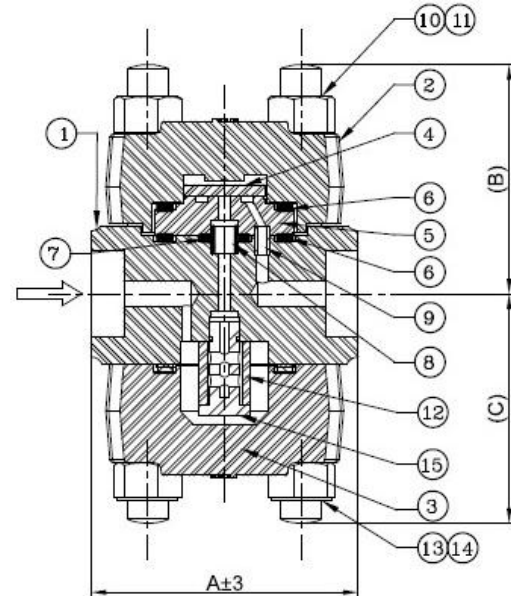

DISCHARGE CAPACITY:

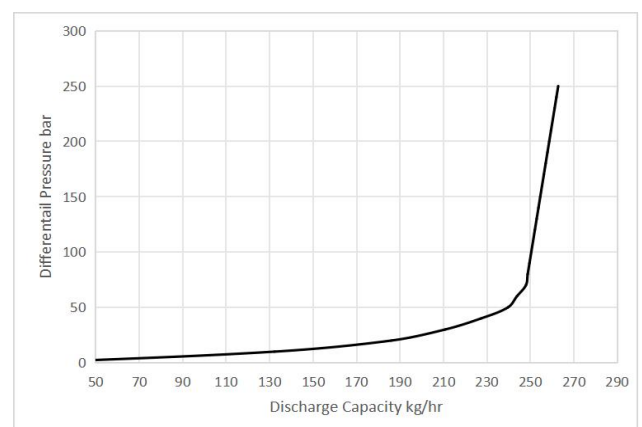

Local regulations may restrict the use of this product below the conditions quoted. Limiting conditions refer to standard connections only. In the interest of development and improvement of the product, we reserve the right to change the specifications without prior notice.