

# PT11H

## THERMODYNAMIC STEAM TRAPS



### DESCRIPTION:

High capacity thermodynamic steam trap with inbuilt strainer, in full stainless steel construction, best suited for header and main line drains and drip legs.

### FEATURES:

Complete stainless steel construction ensures better mechanical and corrosion resistance properties. The disc and seat are hardened by a special induction hardening process with seat harder than disc, to withstand continuous, prolonged operation.

Condensate entry below the disc, concentric to the disc/seat and the three port design ensures a clean and parallel lift of the disc with reference to the seat, reducing localized wear and tear.

The inbuilt strainer screen is of adequately large area.

Ideal for fluctuating loads and pressures.

Able to handle high condensate load.

Perfect shut-off, no steam loss.

**SIZES:** DN15, 20, 25

**CONNECTIONS:** Screwed (NPT/BSPT/BSP)  
Flanged\*, Socket Weld

\*End connection flanges of ASTM A105 forged carbon steel are welded on.

**Non IBR/IBR approved**

### LIMITING CONDITIONS:

PMA: Max. allowable pressure	42 bar(g)
TMA: Max. allowable temperature	425° C
Maximum operating back pressure at the outlet should not exceed 80% of the inlet pressure.	
Minimum differential pressure for satisfactory operation	0.25 bar
Cold hydro test pressure	63 bar(g)

### INSTALLATION:

The trap will operate in any position but the preferred installation is in a horizontal position with the disc cap on the top. Full port isolating valves should be installed upstream and downstream of the trap.

### MAINTENANCE:

This trap can be maintained without disturbing the piping connections. Ensure that the trap is isolated - upstream and downstream - before attempting to dismantle it. ALLOW THE TRAP TO COOL BEFORE DISMANTLING.

For trouble-free performance, periodic cleaning of the disc, seat and strainer screen is recommended.

Do not use abrasive/corrosive media for cleaning. Only the disc and seat are subject to wear.

A worn disc can be replaced. Slight seat wear can often be corrected by resurfacing on a lap plate.

### IMPORTANT:

The trap should be installed as close as possible to the line to be drained.

For new pipelines, ensure that the lines are properly flushed, prior to fitting the traps, to avoid strainer choke-up.

## MATERIAL:

NO.	PART	MATERIAL	QTY. (Nos.)
1.	BODY (Seat Hardened)	ASTM A743 Gr CA 40 (Cast Equiv. AISI 420)	01
2.	DISC CAP	ASTM A743 Gr CA 40 (Cast Equiv. AISI 420)	01
3.	STRAINER CAP	ASTM A743 Gr CA 40 (Cast Equiv. AISI 420)	01
4.	STRAINER SCREEN	AISI 304 (Perforated Sheet 0.8)	01
5.	DISC (Hardened)	AISI 410	01
6.*	ISOTUB	AISI 304	01

## \*OPTIONAL FITTINGS:

**ISOTUB:** An insulating cover reduces the effect of excessive heat loss resulting from low ambient temperatures, wind, rain, etc.

**BLOW DOWN VALVE:** When the blow down valve is opened, loose material collected in the strainer is purged.

## DIMENSIONS:

Nominal in mm

Screwed/Socket Weld Traps

PT11H	A	B	C	D	E	F	Wt.
DN15, 20	80	102	81	90	41	42	1.0 kg
DN25	96	121	91	108	52	50	2.2 kg

Flanged Traps

Model	Size / Rating	G	Wt.( approx.)
PT11H	DN15 / #150	157	2.20 kg
	DN15 / #300	165	2.80 kg
	DN15 / #600	178	3.00 kg
	DN20 / #150	160	2.65 kg
	DN20 / #300	170	3.50 kg
	DN20 / #600	182	3.75 kg
	DN25 / #150	182	4.35 kg
	DN25 / #300	195	5.55 kg
	DN25 / #600	208	5.85 kg

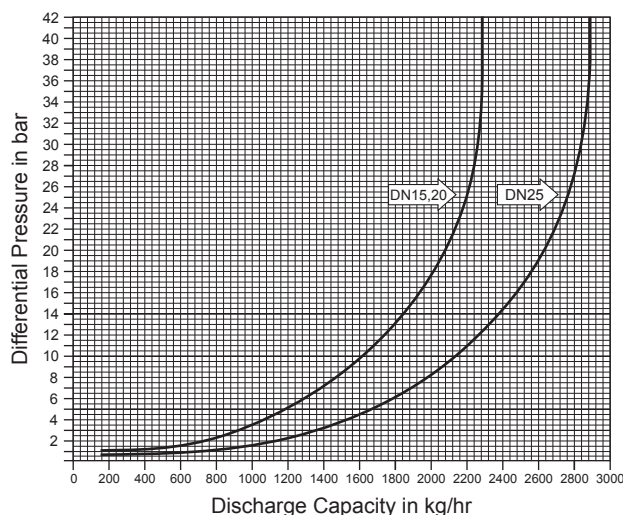
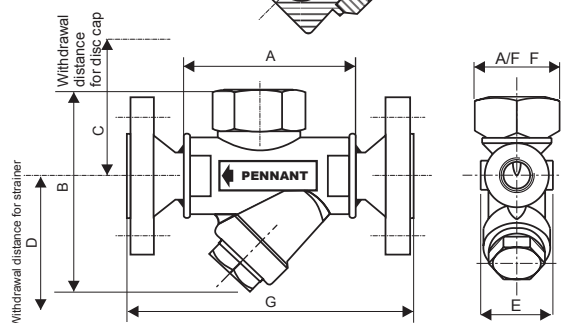
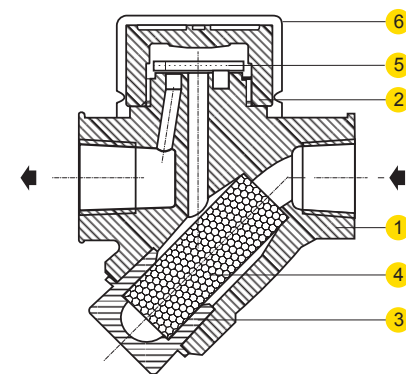

## AVAILABLE SPARES:

Disc, Strainer Screen (Packet of 5), Blow Down Valve, Isotub

## HOW TO ORDER:

PT11H DN15 BSP NIBR

## ORDERING INFORMATION:

- 1) Inlet Pressure in bar(g)
- 2) Back Pressure in bar(g)
- 3) Operating Temperature in °C
- 4) Condensate Load in kg/hr
- 5) Size & Model
- 6) End Connections
- 7) IBR/Non-IBR

Local regulations may restrict the use of this product below the conditions quoted. Limiting conditions refer to standard connections only. In the interest of development and improvement of the product, we reserve the right to change the specifications without prior notice.

All Dimensions are in mm. weights in kg.