

# PC31

## SINGLE DISC NON-SLAM INLINE CHECK VALVES



### DESCRIPTION:

PC31 is a stainless steel inline single disc non slam check valves for general purpose applications. These valves are compact & lighter than the conventional swing check valves. These can be easily fitted in the pipeline.

### FEATURES:

- Can be easily mounted in any plane & direction.
- Can operate under extremely low opening pressure.
- Tested to API 598
- Occupies less space due to its compact design.

**SIZES:** NPS 1/2"-2" Screwed (NPT)

**PRESSURE RATING:** #300

### INSTALLATION:

Inline Check valve can be fixed in any position in the direction of flow.

### MATERIAL:

SR NO	PART NAME	MATERIAL	QTY
1	BODY	ASTM A351 GR. CF8M	01
2	COVER	ASTM A351 GR. CF8M	01
3	COVER GASKET	GRAPHITE	01
4	DISC	AISI 316	01
5	CLIP	AISI 316	01
6	SPRING	AISI 316	01

### DIMENSIONS:

 (approx.) in inches

SIZE	A	B	C	WEIGHT (lbs)
1/2"	1.73	2.28	1.41	0.92
3/4"	2.20	2.44	1.65	1.43
1"	2.44	2.75	1.97	1.98
1 1/4"	3.15	3.35	2.56	4.05
1 1/2"	3.38	3.50	2.56	4.18
2"	3.97	3.97	3.15	6.17

### HOW TO ORDER:

PC31 1/2" NPT

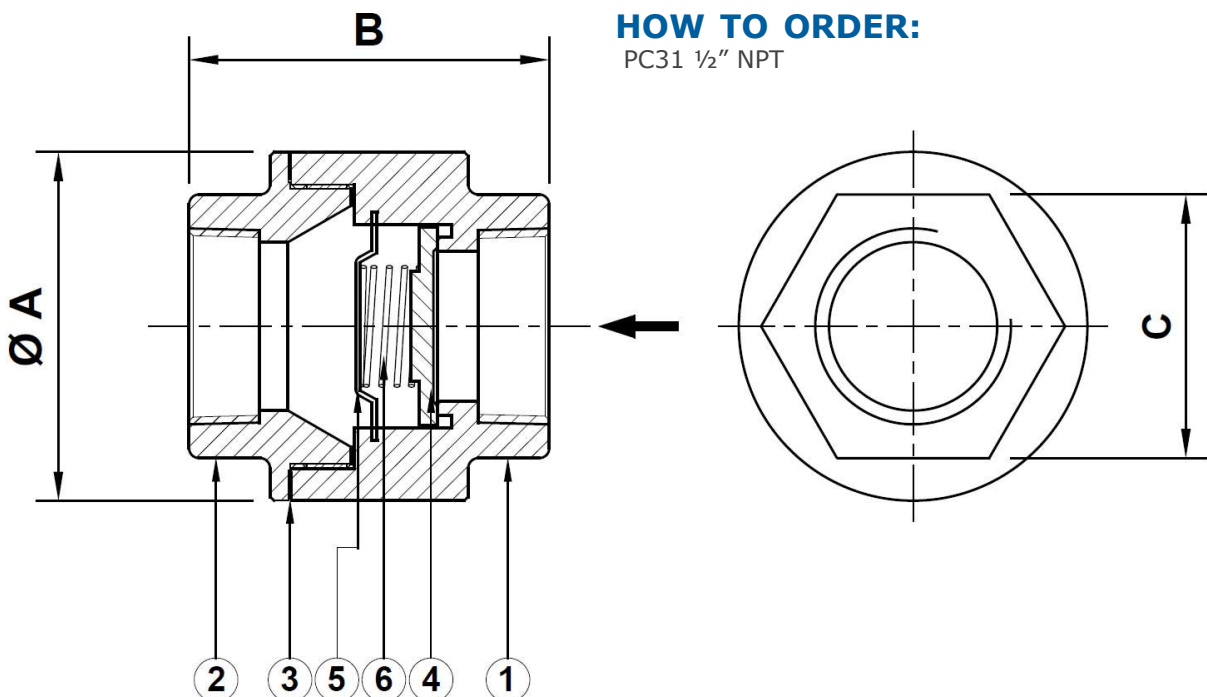

Local regulations may restrict the use of this product below the conditions quoted. Limiting conditions refer to standard connections only. In the interest of development and improvement of the product, we reserve the right to change the specifications without prior notice.

All Dimensions are in inches. weights in lbs.