

PU11/11Y

UNIVERSAL CONNECTOR FOR TRAPS

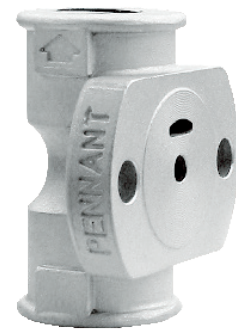

DESCRIPTION:

Universal connector (with and without strainer) for use with steam traps. Facilitates quick replacement of traps reducing maintenance costs.

FEATURES:

The universal connector, once installed, remains in the pipeline permanently. The trap itself is attached to the connector by two bolts, enabling quick installation and replacement. The connector design facilitates vertical/horizontal installation or any angle in-between regardless of piping configuration.

SIZES: NPS 1/2, 3/4

CONNECTIONS: Screwed (NPT/BSPT/BSP)
Socket Weld

LIMITING CONDITIONS:

PMA: Max. allowable pressure	600 psig
TMA: Max. allowable temp.	800 °F
Cold hydro test pressure	900 psig

INSTALLATION:

The connector can be installed in horizontal or vertical lines. The connector face must be in a vertical plane. The trap should be fitted to the connector with its cap uppermost. Full-port isolating valves should be installed upstream and downstream of the connector

MAINTENANCE:

Remove the cap for periodic cleaning of strainer.

IMPORTANT:

While installing connector to pipe, ensure that the connector face is aligned vertically.

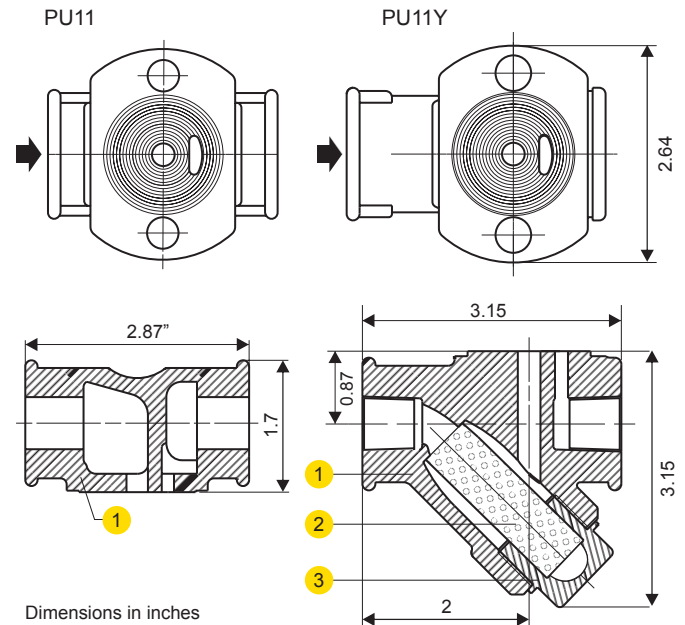

MATERIAL:

NO.	PART	MATERIAL	QTY. (Nos.)
1.	CONNECTOR BODY	ASTM A351 Gr. CF8	01
2.	STRAINER SCREEN	AISI 304 (Perforated Sheet 0.8)	01
3.	STRAINER CAP	ASTM A743 Gr. CA40 (Cast Equiv. AISI 420)	01

WEIGHTS: approx. in lbs

MODEL	SCREWED/ SW ENDS
PU11	1.21
PU11Y	2.25

AVAILABLE SPARES:

Strainer Screen (Packet of 5)

ORDERING INFORMATION:

Refer 'How to Order' page