

PT61

FLOAT & THERMOSTATIC STEAM TRAPS - 1/2", 3/4", 1"



DESCRIPTION:

PT61 float and thermostatic (internal air vent) steam traps are designed for draining condensate from all types of low and medium pressure steam heating and process equipment. Typical applications include unit heaters, heat exchangers, driers and jacketed vessels.

AVAILABLE TYPES:

- PT61 - with Thermostatic Air Vent
- PT61S - with Steam Lock Release (SLR)
- PT61C - with Thermostatic Air Vent & SLR

FEATURES:

Modulating discharge.
Discharges condensate at steam temperature. Excellent air venting (by thermostatic air vent).

USE: Saturated and superheated steam

LIMITING CONDITIONS:

PMA: Max. allowable pressure	250 psig
TMA: Max. allowable temperature	425 °F
PMO: Max. operating pressure	200 psig
TMO: Max. operating temperature	425 °F
Cold hydro test pressure	375 psig

TRAP DISCHARGE CAPACITY IN lbs/hr

MODEL	TRAP SIZE	DIFFERENTIAL PRESSURE (psi)																
		7	15	21.5	28.5	42.5	57	65	70	85	100	115	128	145	157	170	185	200
PT61-65	1/2", 3/4"	440	616	705	770	880	1000	1090	-	-	-	-	-	-	-	-	-	-
PT61-65	1"	1166	1540	1650	1936	2244	2420	2706	-	-	-	-	-	-	-	-	-	-
PT61-145	1/2", 3/4"	297	330	365	396	462	530	560	615	660	770	860	890	925	-	-	-	-
PT61-145	1"	506	704	814	924	1122	1254	1320	1408	1496	1562	1672	1760	1804	-	-	-	-
PT61-200	1/2", 3/4"	275	308	330	363	418	485	506	540	595	650	715	770	825	890	946	1000	1060
PT61-200	1"	285	352	396	484	572	660	704	726	792	836	880	946	990	1012	1045	1078	1122

Recommended safety factor: steady condns. 1.5 - 2; fluctuating condns. 2-3

SIZES: NPS 1/2, 3/4, 1

CONNECTIONS:

Screwed (NPT/BSPT/BSP)

INSTALLATION:

Standard horizontal installation with flow from right to left PT61.

UPON REQUEST:

- Horizontal installation with flow from left to right PT61 (L-R)
- Vertical installation with flow from top to bottom PT61(V)

Max. differential pressure range:

- PT61-4.5 : 65 psi
- PT61-10 : 145 psi
- PT61-14 : 200 psi

The trap should be installed below the drain point of the equipment in a position so that the float arm is in a horizontal plane and the float rises and falls vertically, with the flow direction as indicated on the body. The arrow on the nameplate should be pointing vertically upwards.

MATERIAL:

NO.	PART	MATERIAL
1.	BODY	CAST IRON
2.	COVER	IS : 210 FG20
3.	GASKET (COVER)	Non CAF
4.	VALVE SEAT	AISI 410/ AISI 304
5.	VALVE	AISI 304
6.	LEVER	AISI 304
7.	FLOAT	AISI 304
8.	AIR VENT ASSLY.	AISI 304
9.	BOLT	HIGH TENSILE
10.	DRAIN PLUG	C.S
11.	GASKET DRAIN PLUG	COPPER
12.	GASKET AIR VENT	COPPER
13.	GASKET VALVE SEAT	COPPER
14.	BRACKET ASSLY.	AISI 304
15.	LABEL	AISI 304

*Only for 1" size (Not shown in view)

DIMENSIONS: Nominal in inches

SIZE	A	B	C	D
1/2", 3/4"	5.12	5.75	2.32	4.12
1"	5.71	6.38	2.59	4.12

AVAILABLE SPARES:

Valve Seat, Ball Float & Lever Assly.,
Air Vent Assly., Gaskets.

ORDERING INFORMATION

Refer 'How to Order' page

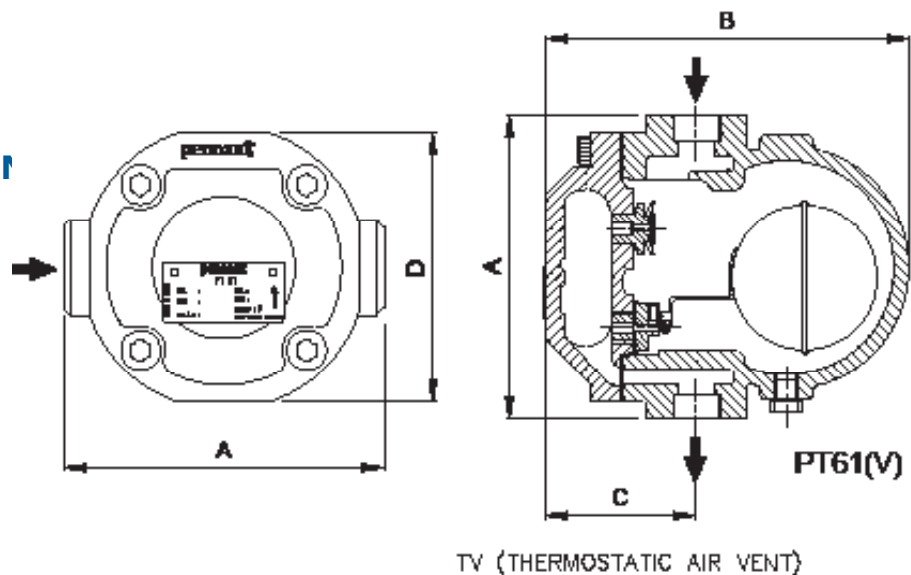
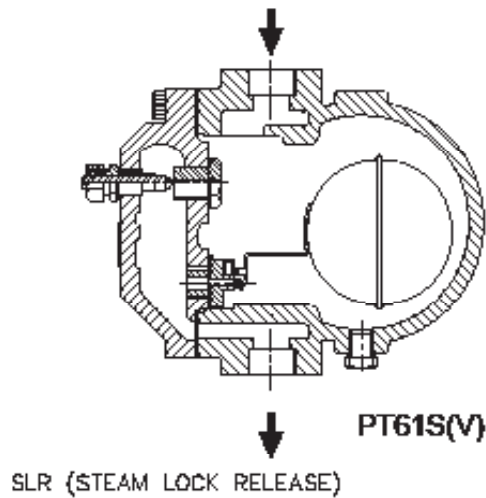
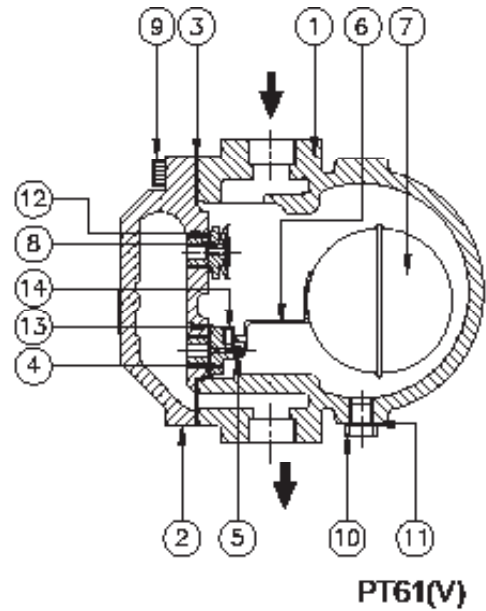

Local regulations may restrict the use of this product below the conditions quoted. Limiting conditions refer to standard connections only. In the interest of development and improvement of the product, we reserve the right to change the specifications without prior notice.