

PT18/PT18Y

THERMODYNAMIC STEAM TRAPS FOR UNIVERSAL CONNECTOR



DESCRIPTION:

Thermodynamic steam trap for fitment on to a universal connector provides a handy solution for maintenance and replacement without disturbing the existing piping.

FEATURES:

The universal connector, once installed, remains in the pipeline permanently. The trap itself is attached to the connector by two bolts, enabling quick installation and replacement. The connector design facilitates vertical/horizontal installation or any angle in-between, regardless of piping configuration.

The trap is of stainless steel construction with integral seat design and hardened disc and seating surface.

SIZES: NPS 1/2, 3/4

CONNECTIONS:

Universal flange connection suitable for mounting on PU11/PU11Y connector
Connectors are supplied in Screwed (NPT/BSPT/BSP), Socket Weld connections.

LIMITING CONDITIONS:

PMA: Max. allowable pressure	600 psig
TMA: Max. allowable temperature	800 °F
Maximum operating back pressure at the outlet should not exceed 80% of the inlet pressure.	
Minimum differential pressure for satisfactory operation	3.5 psig
Cold hydro test pressure	900 psig

INSTALLATION:

The connector can be installed in horizontal or vertical lines. The connector face must be in a vertical plane. The trap should be fitted to the connector with its cap uppermost. Full-port isolating valves should be installed upstream and downstream of the connector.

MAINTENANCE:

The trap can be removed for repair or replacement without disturbing the connector piping connections. Complete isolation of the connector from both supply and return line is required before the trap is removed. The trap should be removed from the connector and inspected and cleaned periodically.

IMPORTANT:

The trap should be installed as close as possible to the line to be drained.
For new pipelines, ensure that the lines are properly flushed, prior to fitting the traps, to avoid strainer choke-up.

MATERIAL:

NO.	PART	MATERIAL	QTY. (Nos)
1.	BODY (Seat Hardened)	ASTM A743 Gr. CA40 (Cast Equiv. AISI 420)	01
2.	CONNECTOR	ASTM A351 Gr. CF8	01
3.	FLANGE	AISI 410	01
4.	DISC CAP	ASTM A743 Gr. CA40 (Cast Equiv. AISI 420)	01
5.	DISC (Hardened)	AISI 410	01
6.	RETAINER RING	STAINLESS STEEL	01
7.& 8.	GASKET	SPIRAL WOUND (SS) WITH GRAFOIL FILLER	02
9.	BOLT	ASTM A193 Gr.B7/SS	02
10.	STRAINER SCREEN	AISI 304 (Perforated Sheet 0.8)	01
11.	STRAINER CAP	ASTM A743 Gr. CA40 (Cast Equiv. AISI 420)	01
12.*	ISOTUB	STAINLESS STEEL	01

Items 2, 10 & 11 are parts of PU11Y

***OPTIONAL FITTINGS:**

ISOTUB: An insulating cover reduces the effect of excessive heat loss resulting from low ambient temperatures, wind, rain, etc.

Blow Down Valve : available only on PU11Y When the blow-down valve is opened, loose material collected in the strainer is purged

DIMENSIONS: Nominal in inches

MODEL	A	B	C	D	E	Wt.
PT18	4.64	3.38	1.69	2.87	2.02	2.53 lbs
PT18Y	6.14	3.38	2.28	3.15	2.02	4.73 lbs

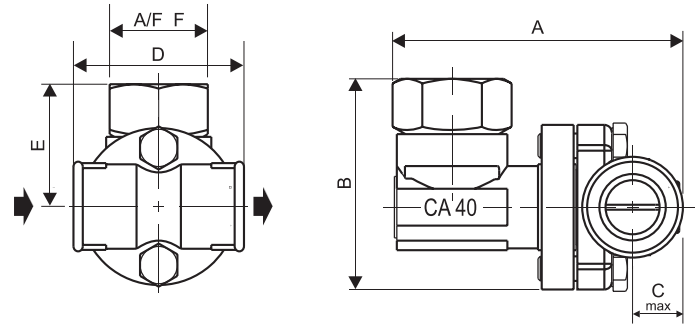

View shows PT18 trap assembled with PU11 connector

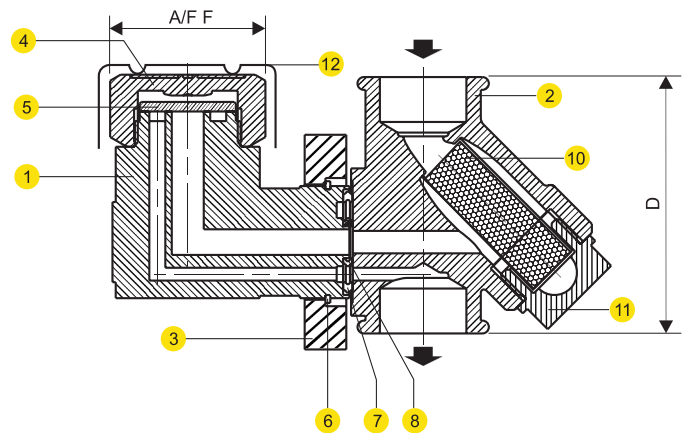
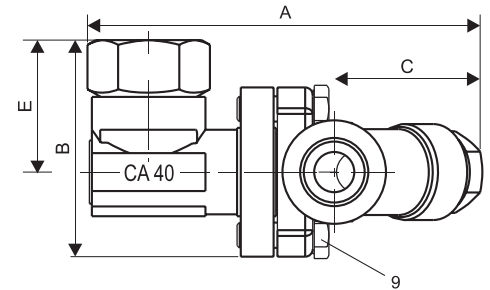

View shows PT18 trap assembled with PU11Y connector

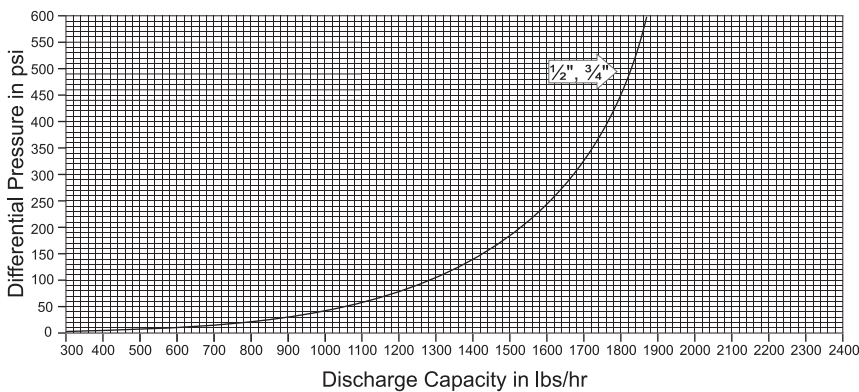

Local regulations may restrict the use of this product below the conditions quoted. Limiting conditions refer to standard connections only. In the interest of development and improvement of the product, we reserve the right to change the specifications without prior notice.

MATERIAL:

NO.	PART	MATERIAL	QTY. (Nos)
1.	BODY (Hardened)	ASTM A743 Gr. CA40 (Cast Equiv. AISI 420)	01
2.	DISC CAP		01
3.	STRAINER CAP		01
4.	STRAINER SCREEN	AISI 304 (Perforated Sheet 0.8)	01
5.	DISC (Hardened)	AISI 410	01
6.	UNIVERSAL FLANGE	AISI 410	01
7.	UNIVERSAL Connector	ASTM A351 Gr. CF8	01
8.	RETAINER RING	STAINLESS STEEL	01
9. & 10.	GASKET	SPIRAL WOUND (SS) WITH GRAFOIL FILLER	02
11.	BOLT	STAINLESS STEEL	02

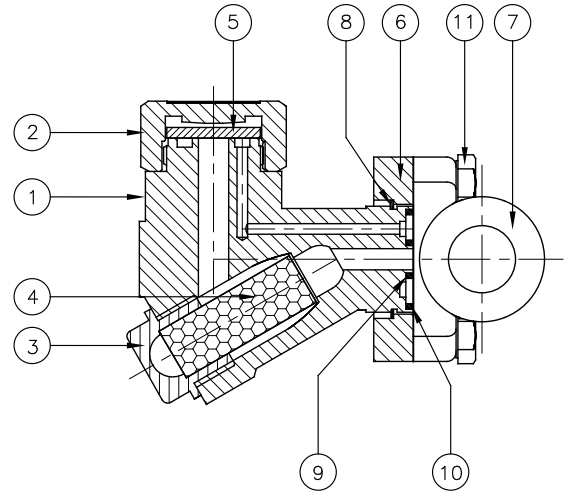

DIMENSIONS:

MODEL	A	B	C	D	E	F	Wt.
PT18Y	4.64	3.93	0.82	2.87	2.04	1.65	2.5

AVAILABLE SPARES:

Disc, Gaskets, Isotub, Strainer Screen (packet of 5), Blow Down Valve

ORDERING INFORMATION:

Refer 'How to Order' page

