

PU11/11Y

UNIVERSAL CONNECTOR FOR TRAPS

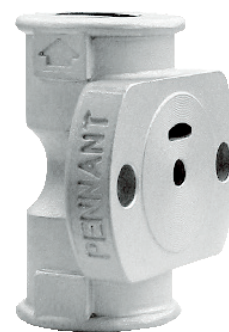

DESCRIPTION:

Universal connector (with and without strainer) for use with steam traps. Facilitates quick replacement of traps reducing maintenance costs.

FEATURES:

The universal connector, once installed, remains in the pipeline permanently. The trap itself is attached to the connector by two bolts, enabling quick installation and replacement. The connector design facilitates vertical/horizontal installation or any angle in-between regardless of piping configuration.

SIZES: DN15, 20

CONNECTIONS:

Screwed (NPT/BSPT/BSP)

Socket Weld

Non IBR/IBR approved

LIMITING CONDITIONS:

PMA: Max. allowable pressure	42 bar(g)
TMA: Max. allowable temp.	426 °C
Cold hydro test pressure	63 bar(g)

INSTALLATION:

The connector can be installed in horizontal or vertical lines. The connector face must be in a vertical plane. The trap should be fitted to the connector with its cap uppermost. Full-port isolating valves should be installed upstream and downstream of the connector.

MAINTENANCE:

Remove the cap for periodic cleaning of strainer.

IMPORTANT:

While installing connector to pipe, ensure that the connector face is aligned vertically.

AVAILABLE SPARES:

Strainer Screen (Packet of 5)

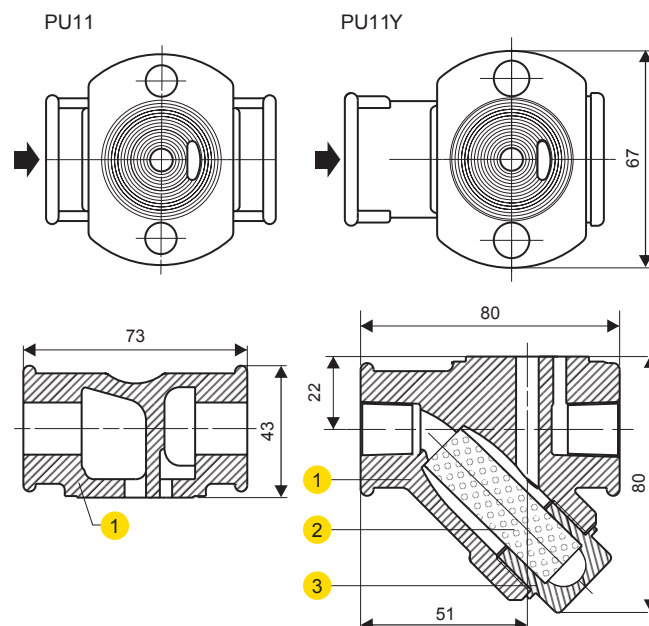

MATERIAL:

No.	PART	MATERIAL	QTY. (Nos.)
1.	CONNECTOR BODY	ASTM A351 Gr. CF8	01
2.	STRAINER SCREEN	AISI 304 (Perforated Sheet 0.8)	01
3.	STRAINER CAP	ASTM A743 Gr. CA40 (Cast Equiv. AISI 420)	01

WEIGHTS: approx. in kg

MODEL	SCREWED/ SW ENDS
PU11	0.550
PU11Y	1.025

HOW TO ORDER:

PU11 DN15 BSP

ORDERING INFORMATION:

- 1) Inlet Pressure in bar(g)
- 2) Operating Temperature in °C
- 3) Size & Model
- 4) End Connections