

Description:

Correct quantity of water to be sprayed, proper atomization, effective evaporation, perfect temperature control etc. are considered by us in designing De-Superheating systems.

The heart of the De-Superheating system is correctly sized spray nozzles. The spray nozzles are so designed to achieve a high degree of atomization even at low differential pressures. The fluctuations in flow are taken care of by a suitably sized spray water control valve. Temperature sensing is done by RTD/TC and spray water flow is controlled by a temperature controller.

Isolating valves, by-pass valves, strainers, non-return valves and inter connected piping are provided to make the system ready for installation at site.

A panel box to install the temperature controller is also included in our scope of supply.

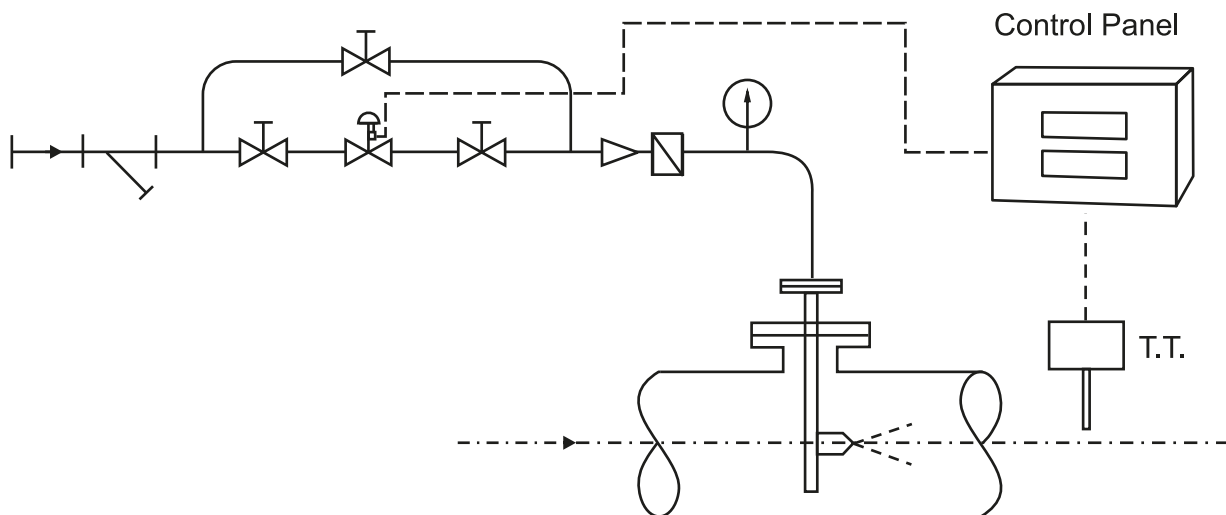

Local regulations may restrict the use of this product below the conditions quoted. Limiting conditions refer to standard connections only. In the interest of development and improvement of the product, we reserve the right to change the specifications without prior notice.