

PPV

PISTON VALVES



DESCRIPTION:

The Pennant Piston Valve (PPV) is a linear movement valve in which a stainless steel piston travels between the upper and lower seal ring. These rings are separated by a lantern bushing, which supports the piston and creates a bubble tight seal. When the valve is in the open position, the upper seal ring in conjunction with the piston prevents leakage through the stem. In the closed position, the lower seal ring seals the valve - passage and provides a tight shutoff. Known for their extraordinary performance and long life, Piston Valves can handle a variety of media such as steam, thermal fluid, condensate and many other liquids and gasses. They can be used in on/off and throttling applications.

FEATURES:

- Bubble tight (ANSI leakage class VI) shutoff
 - Can be used for throttling applications
 - Robust and maintenance free
 - Long service life
 - Effective sealing area is large, as compared to the conventional linear movement valves
 - Performance is not affected by presence of dirt or any other impurities in the media
 - Compensates for thermal expansions with reinforced Grafoil sealing rings and Belleville washers
 - Can be easily serviced inline
 - Easy to repair: The only wearing parts are sealing rings which are easily replaceable
 - Low cost of ownership
- * (Cost of ownership includes maintenance, inventory cost in addition to the purchase cost)

SIZES AND CONNECTIONS:

MOC & END CONNECTION	Sizes									
	DN15	DN20	DN25	DN40	DN50	DN65	DN80	DN100	DN150	DN200
* Forged #800 (Screwed/Socket weld)	•	•	•	•						
Cast # 300 (Screwed/Socket weld)	•	•	•							
Cast #150 (FLANGED ENDS)	•	•	•	•	•		•	•	•	•
Cast #300 (FLANGED ENDS)	•	•	•	•	•	•	•	•	•	•
Cast PN40 (FLANGED ENDS)	•	•	•	•	•					

* Forged #800: DN15, 20, 25 – Angle pattern; DN25, 40 – Straight pattern. Welded-on flanged connections available.

Socket weld ends – as per ASME B16.11
Integral flanged ends - as per ASME B16.5 (#150, #300)
- as per BS EN1092-1 PN40

INSTALLATION:

The valve should be installed in the direction of flow indicated on the body. The valve can be installed in any plane, except with the handwheel on the lower side.

No undue force should be used when tightening the nuts, as they should rotate easily with a standard spanner. Care should be taken while tightening the nuts to avoid tilting of the bonnet. Undue force should not be used to shut the valve as this may damage the spindle or the wheel.

MAINTENANCE:

In case any leakage is observed the bonnet nuts should be tightened with the valve in the fully closed position. Tightening the bonnet nuts may be repeated as and when required until the rings are worn out and no further adjustment or tightening is possible. At this stage the sealing rings need to be replaced.

IMPORTANT:

Always use the recommended tightening torque. Avoid excessive tightening, as this may reduce the life of the sealing rings. Care should be taken while removing the old sealing rings for replacement.

LIMITING CONDITIONS:

Forged	Body design rating	#800 as per API 602
	PMA - Max. permissible pressure	136 barg @ 38 °C
	PMO - Max. permissible operating pressure	76 barg @ 425 °C
Cast - Screwed/SW	Body design rating	#300 as per ASME B16.34
	PMA - Max. permissible pressure	51 barg @ 38 °C
	PMO - Max. permissible operating pressure	28 barg @ 425 °C
Cast - Integral/ Flange #150	Body design rating	#150 as per ASME B16.34
	PMA - Max. permissible pressure	20 barg @ 38 °C
	PMO - Max. permissible operating pressure	5.5 barg @ 425 °C
Cast - Integral/ Flange #300	Body design rating	#300 as per ASME B16.34
	PMA - Max. permissible pressure	51 barg @ 38 °C
	PMO - Max. permissible operating pressure	28 barg @ 425 °C
Cast - Integral/ Flange #PN40	Body design rating	PN40 as per NBSE 1092-1
	PMA - Max. permissible pressure	40 barg @ 38 °C
	PMO - Max. permissible operating pressure	23.3 barg @ 425 °C
Hydrostatic Shell Test	1.5 times the max. rated pressure at 38°C. For IBR-2 times the max. rated pressure at 38°C	
Seat Leakage Test	6 barg air pressure	

FORGED CONSTRUCTION - #800 Scr./SW:

MATERIAL:

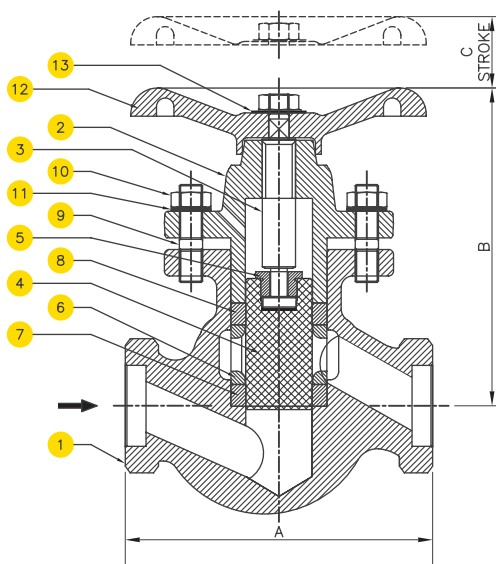

NO.	PART	MATERIAL	QTY.
1.	BODY	ASTM A105	1
2.	BONNET	ASTM A105	1
3.	SPINDLE	AISI 410	1
4.	PISTON	AISI 304	1
5.	SPLIT NUT	BRASS	1
6.	LANTERN BUSH	AISI 304/ ASTM A743 CA15	1
7.	LOWER VALVE RING	GRAFOIL WITH SS	1
8.	UPPER VALVE RING	REINFORCEMENT	1
9.	STUD	ASTM A193 Gr.B7	4
10.	NUT	ASTM A194 Gr.2H	4
11.	BELLEVILLE WASHER	50 Cr V4	8
12.	HANDWHEEL	CAST IRON	1
13.	LABEL	AISI 304	1

CAST CONSTRUCTION - #300 Scr./SW:

MATERIAL:

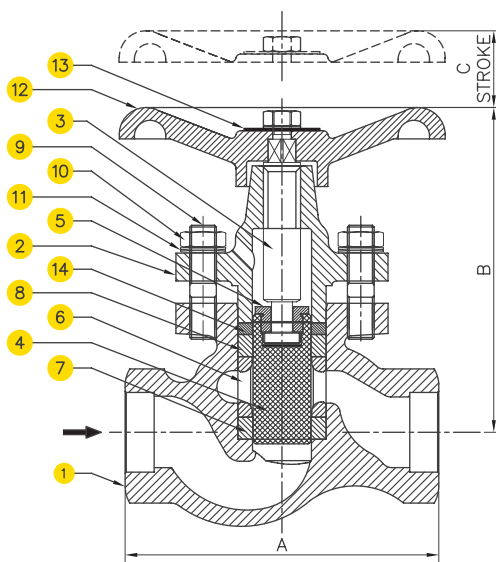

NO.	PART	MATERIAL	QTY.
1.	BODY	ASTM A216 Gr. WCB	1
2.	BONNET	ASTM A216 Gr. WCB	1
3.	SPINDLE	AISI 410	1
4.	PISTON	AISI 304	1
5.	SPLIT NUT	BRASS	1
6.	LANTERN BUSH	AISI 304/ ASTM A743 CA15	1
7.	LOWER VALVE RING	GRAFOIL WITH SS	1
8.	UPPER VALVE RING	REINFORCEMENT	1
9.	STUD	ASTM A193 Gr. B7	*
10.	NUT	ASTM A194 Gr. 2H	*
11.	BELLEVILLE WASHER	50 Cr V4	**
12.	HANDWHEEL	CAST IRON	1
13.	LABEL	AISI 304	1
14.	SPACER	MS	1
*	DN15 : 2 NOS, DN20 : 3NOS , DN25 : 4 NOS		
**	DN15 : 4 NOS, DN20 : 6NOS , DN25 : 8 NOS		

DIMENSION TABLE:

SIZE	FORGED CONSTRUCTION - #800 Scr./SW				CAST CONSTRUCTION - #300 Scr./SW			
	A	B	C	APPROX. WT.	A	B	C	APPROX. WT.
15	101	108	23	2.8	102	108	23	2.8
20	101	125	28	3	120	125	28	3
25	135	130	33	5.5	135	140	33	5.5
40	185	191	44	8.5	-	-	-	-

CAST CONSTRUCTION - INTEGRAL FLGD.:

MATERIAL:

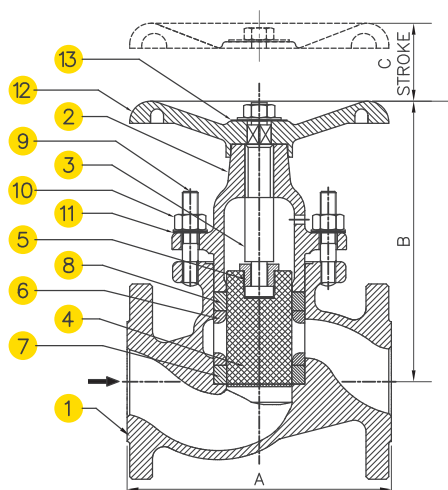

FIG. - DN15~DN50

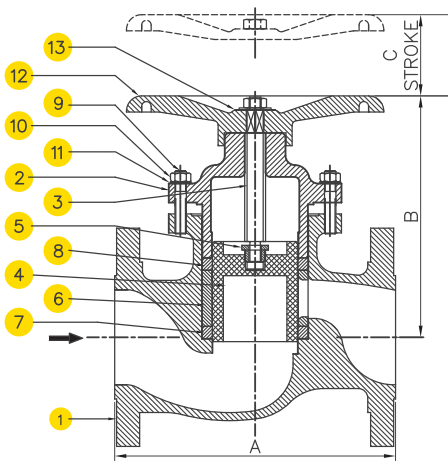

FIG. - DN80~DN150 (UNBALANCED)

NO.	PART	MATERIAL	QTY.
1.	BODY	ASTM A216 Gr. WCB	1
2.	BONNET	ASTM A216 Gr. WCB	1
3.	SPINDLE	AISI 410	1
4.	PISTON	AISI 304	1
5.	SPLIT NUT	BRASS	1
6.	LANTERN BUSH	AISI 304/ ASTM A743 CA15	1
7.	LOWER VALVE RING	GRAFOIL WITH SS	1
8.	UPPER VALVE RING	REINFORCEMENT	1
9.	STUD	ASTM A193 Gr. B7	*
10.	NUT	ASTM A194 Gr. 2H	*
11.	BELLEVILLE WASHER	50 Cr V4	**
12.	HANDWHEEL	CAST IRON	1
13.	LABEL	AISI 304	1
*	DN15-DN50: 4 Nos, DN80: 6Nos, DN100-DN150: 8Nos		
**	DN15-DN50: 8 Nos, DN80: 12Nos, DN100-DN150:16Nos		

DIMENSION TABLE:

SIZE	PISTON VALVE - INTEGRAL FLGD CAST CONSTRUCTION			APPROX. WT.				
	#150	#300	PN40	A	B	C	#150	#300
15	108	152	130	105	23	2.5	3.4	3.2
20	117	178	150	124	28	3	5.5	4.8
25	127	203	160	140	33	4.2	7.4	7
40	165	229	200	189	44	8.5	14.5	12.8
50	203	267	230	215	51	13	20.5	18
80	241	-	-	230	58	24	-	-
100	292	-	-	255	65	45	-	-
150	406	-	-	335	95	86	-	-

BALANCED VALVE (DN65 ~ DN200):

For higher size piston valves - DN65, DN80, DN100, DN150 & DN200, higher torques will be required to operate (close/open) an unbalanced valve against inlet

pressure. Balanced piston valves overcome this higher torque requirement, by balancing the pressure above and below the piston.

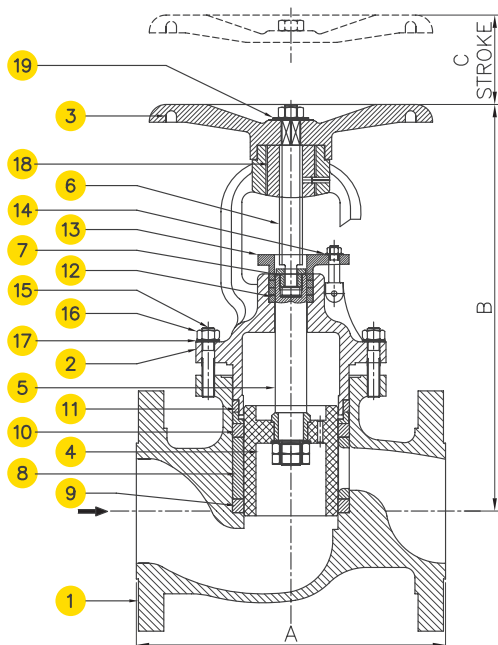

MATERIAL:

NO.	PART	MATERIAL	QTY.
1.	BODY	ASTM A216 Gr. WCB	1
2.	BONNET	ASTM A216 Gr. WCB	1
3.	HANDWHEEL	CAST IRON	1
4.	PISTON	AISI 316/ ASTM A351 Gr. CF8M	1
5.	PISTON SHAFT	AISI 316	1
6.	SPINDLE	AISI 410	1
7.	SPLIT NUT	BRASS	1
8.	LANTERN BUSH	CAST IRON/AISI 304	1
9.	LOWER VALVE RING		1
10.	UPPER VALVE RING	GRAFOIL WITH SS REINFORCEMENT	1
11.	BONNET VALVE RING		1
12.	GLAND VALVE RING		3
13.	GLAND COVER	ASTM A216 Gr. WCB	1
14.	BELLEVILLE WASHER	50 Cr V4 (GLAND)	4
15.	STUD	ASTM A193 Gr. B7	*
16.	NUT	ASTM A194 Gr. 2H	*
17.	BELLEVILLE WASHER	50 Cr V4 (BONNET)	**
18.	THREADED BUSH	CAST IRON	1
19.	LABEL	AISI 304	1
*	DN65: 4 Nos, DN80: 6 Nos, DN100~DN200: 8 Nos		
**	DN65: 8 Nos, DN80:12 Nos, DN100~DN200 :16 Nos		

DIMENSION TABLE:

SIZE	BALANCED DESIGN			APPROX. WT.				
	#150	#300	PN40	B	C	#150	#300	PN40
65	-	292	290	308	50	-	28	27
80	241	318	310	325	58	31	39	38
100	292	356	350	390	65	48	59	57
150	406	445	-	470	95	94	118	-
200	495	559	-	565	120	175	215	-

AVAILABLE SPARES:

DN15~DN50

Sealing ring set
Piston
Spindle

DN15~DN50

Sealing ring set
Bonnet sealing ring
Gland sealing ring set
Piston
Spindle

HOW TO ORDER:

Example: PPV/FCS/DN15/SW, Where

Product Code	Body MOC	Sizes Available	End Connections
PPV	FCS : FORGED CARBON STEEL (ASTM A105)	FORGED (SW/SCR): DN15, 20, 25, 40	SW: Socket Weld
			NPT: SCR NPT
			BSP:SCR BSP
	CCS : CAST CARBON STEEL (ASTM A 216 Gr. WCB)	CAST (SW/SCR): DN15, 20, 25	BSPT:SCR BSPT
			Welded Flange
			SW: Socket Weld
CCS : CAST CARBON STEEL (ASTM A 216 Gr. WCB)	CAST (Flanged End): DN15, 20, 25, 40, 50, 65, 80, 100, 150, 200	NPT: SCR NPT	
		BSP:SCR BSP	
		BSPT:SCR BSPT	
			F1: Flanged End #150
			F3: Flanged End #300
			PN40: Flanged End PN40

ORDERING INFORMATION:

1. Operating pressure
2. Operating temperature
3. Size
4. End connections
5. Service fluid