

PT18/PT18Y

THERMODYNAMIC STEAM TRAPS WITH UNIVERSAL CONNECTOR



DESCRIPTION:

Thermodynamic steam trap for fitment on to a universal connector provides a handy solution for maintenance and replacement without disturbing the existing piping.

FEATURES:

The universal connector, once installed, remains in the pipeline permanently. The trap itself is attached to the connector by two bolts, enabling quick installation and replacement. The connector design facilitates vertical/horizontal installation or any angle in-between, regardless of piping configuration.

The trap is of stainless steel construction with integral seat design and hardened disc and seating surface.

SIZES: DN15, 20,

CONNECTIONS:

Universal flange connection suitable for mounting on PU11/PU11Y connector
Connectors are supplied in Screwed (NPT/BSPT/BSP), Socket weld connections.

Non IBR/IBR approved

LIMITING CONDITIONS:

PMA: Max. allowable pressure	42 bar(g)
TMA: Max. allowable temperature	425° C
Maximum operating back pressure at the outlet should not exceed 80% of the inlet pressure.	
Minimum differential pressure for satisfactory operation	0.25 bar
Cold hydro test pressure	63 bar(g)

INSTALLATION:

The connector can be installed in horizontal or vertical lines. The connector face must be in a vertical plane. The trap should be fitted to the connector with its cap uppermost. Full-port isolating valves should be installed upstream and downstream of the connector.

MAINTENANCE:

The trap can be removed for repair or replacement without disturbing the connector piping connections. Complete isolation of the connector from both supply and return line is required before the trap is removed. The trap should be removed from the connector and inspected and cleaned periodically.

IMPORTANT:

The trap should be installed as close as possible to the line to be drained.

For new pipelines, ensure that the lines are properly flushed, prior to fitting the traps, to avoid strainer choke-up.

MATERIAL:

No.	PART	MATERIAL	QTY. (Nos)
1.	BODY (Seat Hardened)	ASTM A743 Gr. CA40 (Cast Equiv. AISI 420)	01
2.	CONNECTOR	ASTM A351 Gr. CF8	01
3.	FLANGE	AISI 410	01
4.	DISC CAP	ASTM A743 Gr. CA40 (Cast Equiv. AISI 420)	01
5.	DISC (Hardened)	AISI 410	01
6.	RETAINER RING	STAINLESS STEEL	01
7.& 8.	GASKET	SPIRAL WOUND (SS) WITH GRAFOIL FILLER	02
9.	BOLT	STAINLESS STEEL	02
10.	STRAINER SCREEN	AISI 304 (Perforated Sheet 0.8)	01
11.	STRAINER CAP	ASTM A743 Gr. CA40 (Cast Equiv. AISI 420)	01
12.*	ISOTUB	AISI 304	01

Items 2, 10 & 11 are parts of PU11Y

***OPTIONAL FITTINGS:**

ISOTUB: An insulating cover reduces the effect of excessive heat loss resulting from low ambient temperatures, wind, rain, etc.

BLOW DOWN VALVE: (Available only in PU11Y) When the blow down valve is opened, loose material collected in the strainer is purged.

DIMENSIONS:

Nominal in mm

MODEL	A	B	C	D	E	F	Wt.
PT18	118	86	43	73	52	42	1.15 kg

AVAILABLE SPARES:

Disc, Gaskets, Isotub.

HOW TO ORDER:

PT18 DN15 NIBR only Or
PT18 DN15 NIBR with connector (PU11/PU11Y)
BSP/BSPT/NPT/Socket Weld

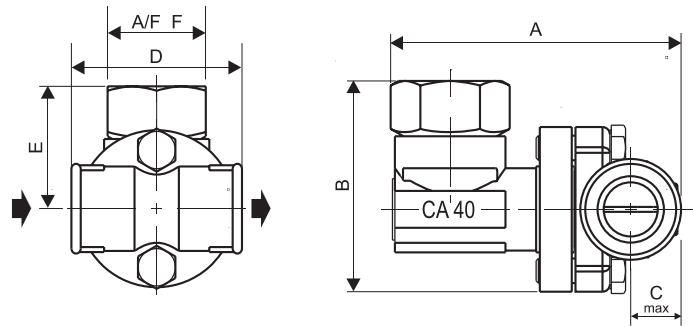

View shows PT18 trap assembled with PU11 connector

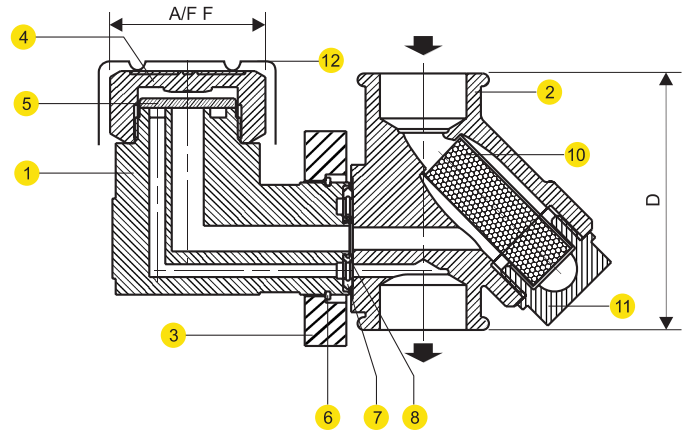
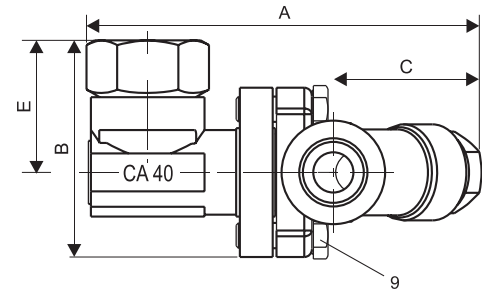

View shows PT18 trap assembled with PU11Y connector

MATERIAL:

No.	PART	MATERIAL	QTY. (Nos)
1.	BODY (Hardened)	ASTM A743 Gr. CA40 (Cast Equiv. AISI 420)	01
2.	DISC CAP		01
3.	STRAINER CAP		01
4.	STRAINER SCREEN	AISI 304 (Perforated Sheet 0.8)	01
5.	DISC (Hardened)	AISI 410	01
6.	UNIVERSAL FLANGE	AISI 410	01
7.	UNIVERSAL CONNECTOR	ASTM A351 Gr. CF8	01
8.	RETAINER RING	STAINLESS STEEL	01
9. & 10	GASKET	SPIRAL WOUND (SS) WITH GRAFOIL FILLER	02
11.	BOLT	STAINLESS STEEL	02

*OPTIONAL FITTINGS:

ISOTUB: An insulating cover reduces the effect of excessive heat loss resulting from low ambient temperatures, wind, rain, etc.

BLOW-DOWN VALVE: (Available only in PU11Y) When the blow-down valve is opened, loose material collected in the strainer is purged.

DIMENSIONS:

Nominal in mm

MODEL	A	B	C	D	E	F	Wt.
PT18Y	118	100	21	73	52	42	1.15

AVAILABLE SPARES:

Disc, Gaskets, Isotub.

HOW TO ORDER:

PT18 DN15 NIBR only Or

PT18 DN15 NIBR with connector (PU11/PU11Y)

BSP/BSPT/NPT/Socket Weld

ORDERING INFORMATION:

- 1) Inlet Pressure in bar(g)
- 2) Back Pressure in bar(g)
- 3) Operating Temperature in °C
- 4) Condensate Load in kg/hr
- 5) Size & Model
- 6) IBR / Non-IBR

