

PT64H

FLOAT & THERMOSTATIC STEAM TRAPS



DESCRIPTION:

PT64H float and thermostatic (integral air vent) steam traps are designed for draining condensate from building heating installations and other low pressure and high condensation applications.

FEATURES:

Modulating discharge of hot condensate at close to saturation temperature. Good air venting facilitates a fast start-up. Suitable for high condensate load.

USE: Saturated and superheated steam.

SIZES: NPS 2

CONNECTIONS: Screwed (NPT/BSPT/BSP)

LIMITING CONDITIONS:

PMA: Max. allowable pressure	225 psig
TMA: Max. allowable temperature	425 °F
PMO: Max. operating pressure	50 psig
TMO: Max. operating temperature	425 °F
Cold hydro test pressure	375 psig

INSTALLATION:

It is important to install the trap with the label on the top and the connecting pipes horizontal. Inlet and outlet connections are marked on the housing. For effective condensate removal, the trap should be fitted below the drain point of the system being drained.

WEIGHT (approx.) : 29 lbs

TRAP DISCHARGE CAPACITY IN lbs/ hr

MODEL	TRAP SIZE	DIFFERENTIAL PRESSURE (psi)										
		1/4	1/2	1	2	5	10	15	20	30	40	50
PT64H-50	2"	4000	5500	7000	9500	11000	12800	13800	16000	17300	18400	20600

MATERIAL:

NO.	PART	MATERIAL	QTY. Nos.
1.	BODY	CAST IRON	01
2.	COVER	CAST IRON	01
3.	BALL FLOAT & LEVER ASSY.	AISI 304	01
4.	VALVE	AISI 410/420	02
5.	VALVE SEAT		02
6.	AIR VENT	STAINLESS STEEL	01
7.	GASKET	NON CAF	01
8.	DRAIN PLUG	CARBON STEEL	01
9.	BOLT	HIGH TENSILE	08

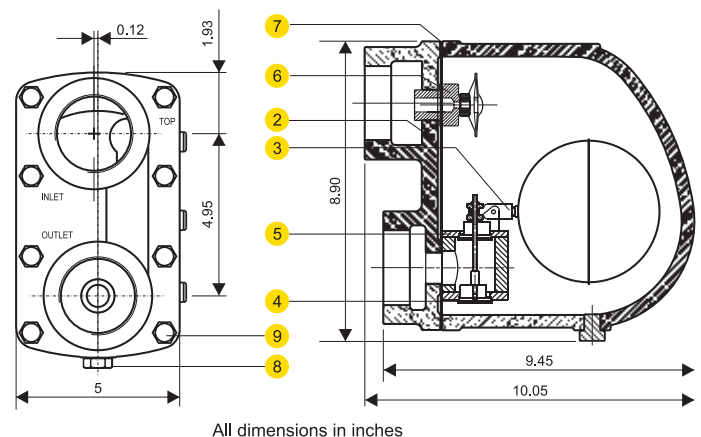

AVAILABLE SPARES:

Valve Seat, Ball Float & Lever Assly., Air Vent Assly., Gaskets

ORDERING INFORMATION:

Refer 'How to Order' page.