

PT62

FLOAT & THERMOSTATIC STEAM TRAPS - 1/2", 3/4", 1"



DESCRIPTION:

PT62 float and thermostatic (internal air vent) steam traps are designed for draining condensate from all types of low and medium pressure steam heating and process equipment. Typical applications include unit heaters, heat exchangers, driers and jacketed vessels. Horizontal installation.

AVAILABLE TYPES:

- PT62 - with thermostatic air vent
- PT62S - SLR (with steam lock release)
- PT62C - with thermostatic air vent and SLR

FEATURES:

- Modulating discharge.
- Discharges condensate at steam temperature.
- Excellent air venting (by thermostatic air vent).

USE:

Saturated and superheated steam.

SIZES:

NPS 1/2, 3/4, 1

CONNECTIONS:

Screwed (NPT, BSPT, BSP)
Flanged*/ Socket Weld

*End connection flanges of ASTM A105 forged carbon steel are welded on.

LIMITING CONDITIONS:

PMA: Max. allowable pressure	250 psig
TMA: Max. allowable temperature	425 °F
PMO: Max.. operating pressure	200 psig
TMO: Max. operating temperature	425 °F
Body shell design rating	285 psig 800 °F
Cold hydro test pressure	375 °F

INSTALLATION:

Horizontal installation with flow from left to right. The trap should be installed horizontally below the drain point of the equipment in a position such that the float arm is in a horizontal plane and the float rises and falls vertically, with the flow direction as indicated on the cover.

The word 'TOP' on the nameplate indicates the top side of the trap.

Max. differential pressure range:

- PT62-4.5 : 65 psi
- PT62-10 : 145 psi
- PT62-14 : 200 psi

TRAP DISCHARGE CAPACITY IN lbs/hr

MODEL	TRAP SIZE	DIFFERENTIAL PRESSURE (psi)																
		7	15	21.5	28.5	42.5	57	65	70	85	100	115	128	145	157	170	185	200
PT62-65	1/2", 3/4"	440	616	705	770	880	1000	1090	-	-	-	-	-	-	-	-	-	-
PT62-65	1"	1850	2080	2310	2540	2990	3455	3685	-	-	-	-	-	-	-	-	-	-
PT62-145	1/2", 3/4"	297	330	365	396	462	530	560	615	660	770	860	890	925	-	-	-	-
PT62-145	1"	1330	1440	1562	1672	1915	2145	2255	2376	2610	2840	3070	3300	3530	-	-	-	-
PT62-200	1/2", 3/4"	275	308	330	363	418	485	506	540	595	650	715	770	825	890	946	1000	1060
PT62-200	1"	935	1000	1056	1122	1243	1365	1420	1485	1606	1725	1848	1970	2090	2210	2343	2465	2585

Recommended safety factor: steady condns. 1.5 - 2; fluctuating condns. 2-3

MATERIAL:

NO.	PART	MATERIAL	QTY. (Nos.)
1.	BODY	ASTM A216 Gr. WCB	01
2.	COVER	ASTM A216 Gr. WCB	01
3.	GASKET	NON CAF	01
4.	VALVE SEAT	AISI 410/420	01
5.	BALL FLOAT & LEVER ASSY.	AISI 304	01
6.	AIR VENT	STAINLESS STEEL	01
7.	BOLT	ASTM A193 Gr. B7	04
8.	DRAIN PLUG	CARBON STEEL	01
9.	BRACKET ASSY.	AISI 304	01
10.	GASKET	COPPER	01
11.	SLR UNIT	AISI 304	01

DIMENSIONS: Nominal in inches

SIZE	A	B	C	D	E	F	
						#150	#300
1/2"	3.95	5.50	4.10	2.00	6.50	6.90	7.30
3/4"	3.95	5.50	4.10	2.00	6.50	7.10	7.50
1"	4.75	7.4	6.5	4.15	8.65	8.5	8.66

H	G
1 1/2" SCR	8.10
2" SCR	8.25
1 1/2" SW	7.70
2" SW	7.90

AVAILABLE SPARES:

Valve Seat, Ball Float & Lever Assly.,
Airvent Assly., Gaskets

ORDERING INFORMATION:

Refer 'How to Order' page.

WEIGHTS: (approx in lbs)

SIZE	SCR/SW ENDS	FLANGED ENDS	
		#150	#300
1/2"	9.9	12.0	13.0
3/4"	9.9	12.8	14.3
1"	16.5	25.3	27.5

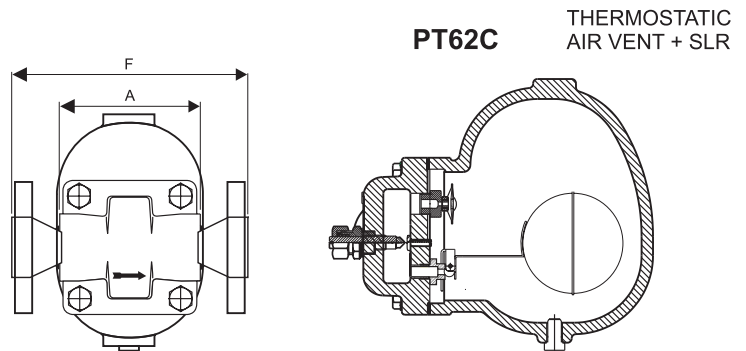
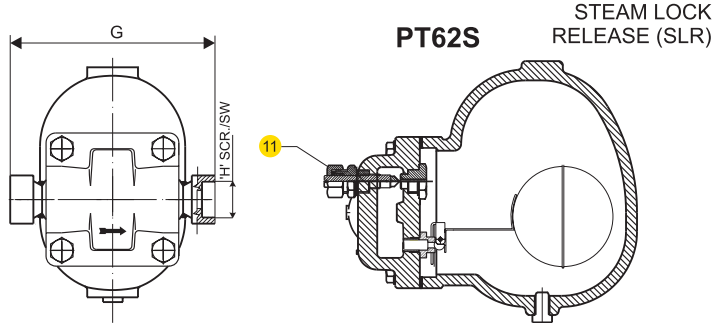
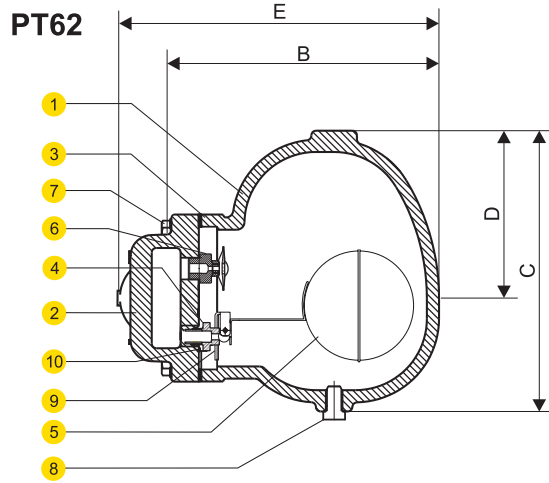

Local regulations may restrict the use of this product below the conditions quoted. Limiting conditions refer to standard connections only. In the interest of development and improvement of the product, we reserve the right to change the specifications without prior notice.

PT62

FLOAT & THERMOSTATIC STEAM TRAPS - 1½", 2"

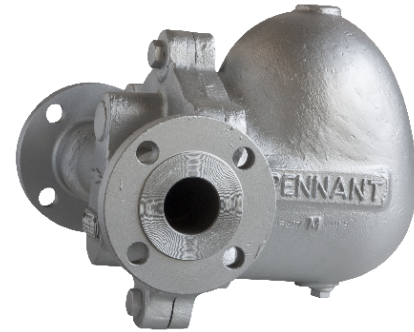

DESCRIPTION:

PT62 float and thermostatic (internal air vent) steam traps are designed for draining condensate from all types of low and medium pressure steam heating and process equipment. Typical applications include unit heaters, heat exchangers, driers and jacketed vessels. Horizontal installation.

AVAILABLE TYPES:

- PT 62 - with thermostatic air vent
- PT 62S - SLR (with steam lock release)
- PT 62C - with thermostatic air vent and SLR.

FEATURES:

- Modulating discharge.
- Discharges condensate at steam temperature.
- Excellent air venting (by thermostatic air vent).

USE:

Saturated and superheated steam.

SIZES:

NPS 1½, 2

CONNECTIONS: Screwed (NPT/BSPT/BSP)
Flanged / Socket weld

LIMITING CONDITIONS:

PMA: Max. allowable pressure	250 psig
TMA: Max. allowable temperature	425 °F
PMO: Max. operating pressure	200 psig
TMO: Max. operating temperature	425 °F
Body shell design rating	285 psig 800 °F
Cold hydro test pressure	375 psig

INSTALLATION:

Horizontal installation with flow from left to right. The trap should be installed horizontally below the drain point of the equipment in a position such that the float arm is in a horizontal plane and the float rises and falls vertically, with the flow direction as indicated on the cover.

The arrow on the nameplate should be pointing vertically upwards.

Max. differential pressure range:

- PT62-4.5 : 65 psi
- PT62-10 : 145 psi
- PT62-14 : 200 psi

TRAP DISCHARGE CAPACITY IN lbs/hr

MODEL	TRAP SIZE	DIFFERENTIAL PRESSURE (psi)																
		7	15	21.5	28.5	42.5	57	65	70	85	100	115	128	145	157	170	185	200
PT62-65	1½", 2"	6655	7205	7755	8340	9460	10560	11135	-	-	-	-	-	-	-	-	-	-
PT62-145	1½", 2"	4920	5910	6270	6430	6820	7350	7525	7765	8150	8875	9700	10550	11275	-	-	-	-
PT62-200	1½", 2"	4280	4995	5590	6115	6545	6820	6995	7160	7415	7975	8560	9085	9615	10100	10560	11000	11430

Recommended safety factor: steady condns. 1.5 - 2; fluctuating condns. 2-3

MATERIAL:

NO.	PART	MATERIAL	QTY. (Nos.)
1.	BODY	ASTM A216 Gr. WCB	01
2.	COVER	ASTM A216 Gr. WCB	01
3.	GASKET	NON CAF	01
4.	VALVE SEAT	AISI 420 / ASTM A743 Gr. CA40	01
5.	BALL FLOAT & LEVER ASSY.	AISI 304	01
6.	AIR VENT	STAINLESS STEEL	01
7.	BOLT	ASTM A193 Gr. B7	06
8.	DRAIN PLUG	CARBON STEEL	01
9.	BRACKET ASSY.	AISI 304	01
10.	SLR UNIT	AISI 304	01

WEIGHTS: (approx.)

SCREWED/SW	FLANGED
68 lbs	77 lbs

AVAILABLE SPARES:

Valve Seat, Ball Float & Lever Assly.,
Air Vent Assly., Gaskets

ORDERING INFORMATION:

Refer 'How to Order' page

PT62

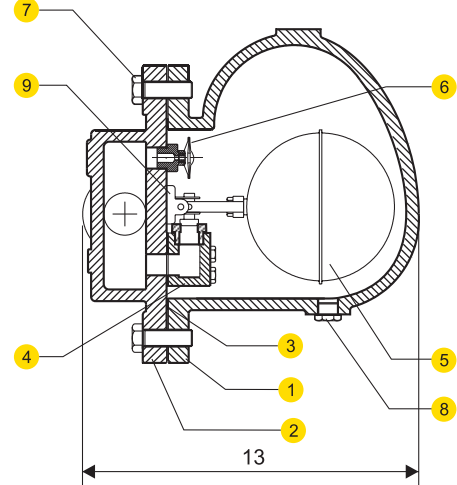

PT62S

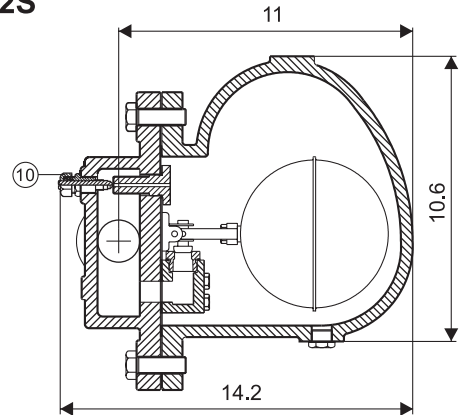

PT62C

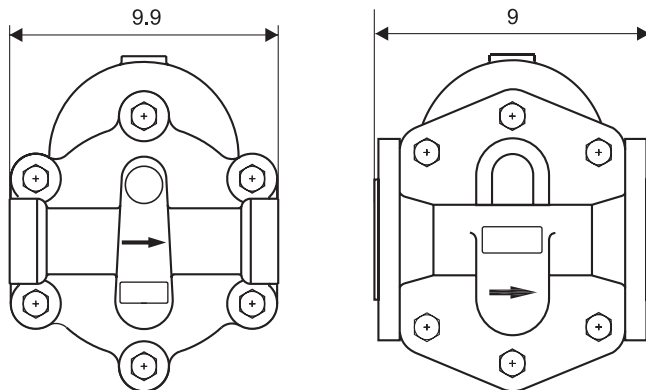
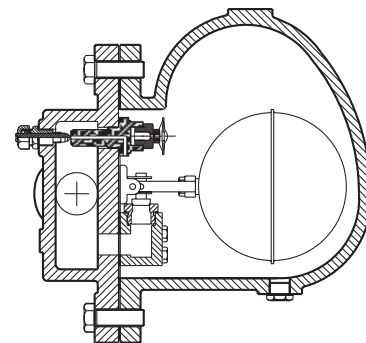

DIMENSIONS - Nominal in inches

Local regulations may restrict the use of this product below the conditions quoted. Limiting conditions refer to standard connections only. In the interest of development and improvement of the product, we reserve the right to change the specifications without prior notice.