

# PD21

## LIQUID DRAIN TRAPS (CAST IRON)



### DESCRIPTION:

Liquid drain trap with all stainless steel internals. Best suited for removal of oil or liquids from the compressed air systems.

### FEATURES:

The inverted bucket arrangement operates on the density difference between compressed air and water, giving a cyclic operation for discharge of the accumulated moisture / liquids from compressed air / gas systems. The valve and valve seat are hardened by a special induction hardening process to withstand continuous, prolonged operation. Perfect shut-off, no air loss.

**SIZES:** NPS 1/2, 3/4, 1, 1½

### CONNECTIONS:

Screwed (NPT/BSPT/BSP)

### LIMITING CONDITIONS:

PMA: Max. allowable pressure	250 psig
TMA: Max. allowable temp.	428 °F
Maximum operating back pressure at the outlet should not exceed 90% of the inlet pressure	
Minimum diff. pressure for satisfactory operation	1.5 psi
Cold hydro test pressure	375 psig

### INSTALLATION:

The trap must be fitted vertically, with the inlet from the bottom and the outlet at the top. Correct vertical fitment is essential for easy movement of the bucket. Care must be taken to ensure that the trap level is below the level of the equipment to be drained. The bypass arrangement should be above the level of the trap. Fitment of a strainer before the trap inlet is recommended to prevent entry of dirt / foreign particles into the trap. Full-port isolation valves should be fitted before and after the trap, to be used when the trap has to be opened for maintenance.

### IMPORTANT:

Ensure that the trap is primed by opening the inlet valve only a crack, at commissioning, allowing water to fill the trap before the steam enters. The inlet valve should be opened fully only after the trap is filled with water.

The trap should be installed as close as possible to the equipment to be drained. For new pipelines, ensure that the lines are properly flushed, prior to fitting the trap.

### MAINTENANCE:

This product has to be removed from the line for maintenance. It is recommended that the trap be opened periodically and the internals inspected for wear, damage, and dirt. All worn or damaged parts should be replaced with new spares. A new internal kit comprising of the valve pin, valve seat, bracket and lever should be replaced as a set. The bucket vent hole should be cleaned.

## MATERIAL:

NO.	PART	MATERIAL	QTY.
1.	BODY	CAST IRON	01
2.	COVER	CAST IRON	01
3.	BUCKET ASSLY.	AISI 304 with CS reinforcing ring	01
4.	VALVE SEAT (Hardened)	AISI 410/420	01
5.	VALVE PIN (Hardened)		01
6.	BRACKET	AISI 304	01
7.	LEVER	AISI 304	01
8.	PLUG	CARBON STEEL	01
9.	GASKET	Non CAF	01
10.	BOLT	HIGH TENSILE	*
11.	NUT	HIGH TENSILE	*
12.	PIPE	CARBON STEEL	01

Note: All internal screws are AISI 304

\*Sizes NPS 1/2, 3/4 - 6 Nos., 1, 1½ - 8 Nos.

## DIMENSIONS:

Nominal in inches

MODEL	SIZE	ØA	B	Wt.
PD21	½"	4.53	6.1	8.15 lbs
	¾"	4.53	6.69	9.25 lbs
	1"	7.32	11.1	35.20 lbs
	1½"	8.39	11.81	41.80 lbs

## AVAILABLE SPARES:

Spare Kit: Valve Pin, Valve Seat, Bracket & Lever Assly.,  
(Op. diff. press. should be specified.)  
Bucket Assly., Gasket.

## ORDERING INFORMATION:

Refer 'How to Order' page

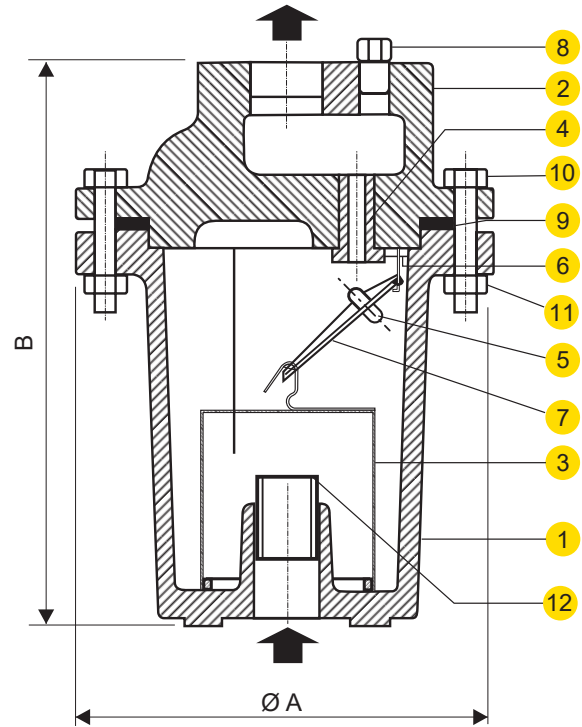

## ORDERING INFORMATION:

Refer 'How To Order Page'

### CAUTION:

DO NOT USE FOR HAZARDOUS/POISONOUS MEDIA

Local regulations may restrict the use of this product below the conditions quoted. Limiting conditions refer to standard connections only. In the interest of development and improvement of the product, we reserve the right to change the specifications without prior notice.